

**I** **Emulatore Sonda Lambda OBD2 -  $\mu$ FIX Codice 425**  
Schemi d'installazione  
*Elenco vetture su cui installare l'Emulatore Sonda Lambda OBD2 -  $\mu$ FIX Codice 425.*  
*L'elenco delle vetture potrà essere aggiornato da A.E.B. in qualsiasi momento.*

**GB** **Lambda Feeler Emulator OBD2 -  $\mu$ FIX Code 425**  
Installation diagrams  
*List of the cars on which to install the Lambda Feeler Emulator OBD2 -  $\mu$ FIX Code 425.*  
*The car list can be updated by A.E.B. at any moment.*

**F** **Emulateur Sonde Lambda OBD2 -  $\mu$ FIX Code 425**  
Schémas d'installation  
*Liste des voitures sur lesquelles installer l'Emulateur Sonde Lambda OBD2 -  $\mu$ FIX Code 425.*  
*La liste des voitures pourra être actualisée par A.E.B. à tout moment.*

**E** **Emulador Sonda Lambda OBD2 -  $\mu$ FIX Código 425**  
Esquemas de instalación  
*Lista de los coches sobre los cuales el Emulador Sonda Lambda OBD2 -  $\mu$ FIX Código 425.*  
*La lista de los coches podrá ser actualizado por A.E.B. en cualquier momento.*

**P** **Emulador Sonda Lambda OBD2 -  $\mu$ FIX Código 425**  
Esquema de instalação  
*Lista de viaturas sobre as quias instalar o Emulador Sonda Lambda OBD2 -  $\mu$ FIX Código 425.*  
*A lista das viaturas poderá ser actualizada pela A.E.B. em qualquer momento.*

ITALIANO

ENGLISH

FRANCAIS

ESPAÑOL

PORTUGUES

## Indice - Index - Table OBD II - μFIX Cod. 425

<b>AUDI</b>	INIEZIONE - INJECTION INYECCION - INJEÇÃO	SCHEMA - DIAGRAM SCHEMA - ESQUEMA ESQUEMA
A2 1.4i 16v	Multipoint MARELLI - AUA	5
A3 1.8i 20v	Multipoint BOSCH - APG	4
<b>SKODA</b>		
Felicia 1.4i	Mpi SIEMENS 5WP44	1
Fabia 1.4i	Mpi SIEMENS 5WP44 - ATZ	1
Fabia 1.4i 16v	Mpi MARELLI IAW 4LVC	5
Octavia 1.6i	Mpi SIEMENS 5WP400 - AVU	4
<b>SUBARU</b>		
Forester 2.0i 16v	Multipoint	4
<b>VOLKSWAGEN</b>		
Polo 1.0i	Mpi BOSCH ME 7.5	4
Polo 1.4i	Multipoint BOSCH - AKK	1
Polo 1.4i 16v	Mpi MARELLI IAW 4LV.KA	2
Golf 1.4i 16v	Multipoint BOSCH	1
Golf 1.6i	Mpi SIEMENS 5WP400 - APF	4
Golf 1.6i 16v	Mpi MARELLI IAW 4LVH - AUS	8
Bora 1.6i 16v	Multipoint MARELLI - AZD	8
Sharan 2.8i V6	Multipoint BOSCH	4
<b>VOLVO</b>		
V70 2.0i 20v Turbo	Mpi BOSCH - B5204T5	4

## Indice - Index - Table OBD II - μFIX Cod. 425 + Adapter 349

<b>HONDA</b>	INIEZIONE - INJECTION INYECCION - INJEÇÃO	SCHEMA - DIAGRAM SCHEMA - ESQUEMA ESQUEMA
Accord 2.0i 16v V - Tec	Multipoint - F20B2	3
<b>TOYOTA</b>		
Rav 4 2.0i 16v VVT - i	Multipoint	6
<b>VOLVO</b>		
S60 2.4i 20v	Multipoint DENSO - B5244S	7

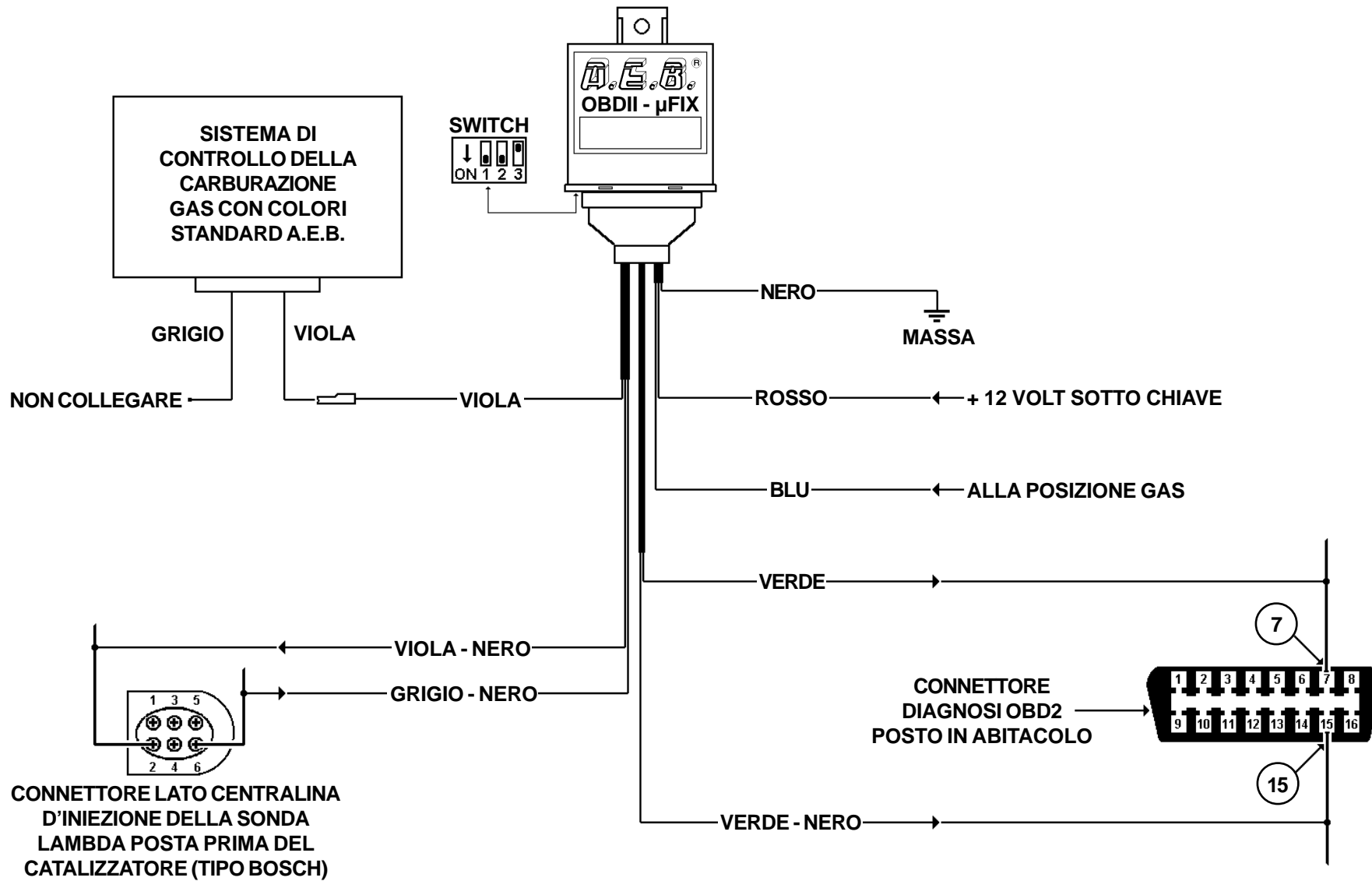

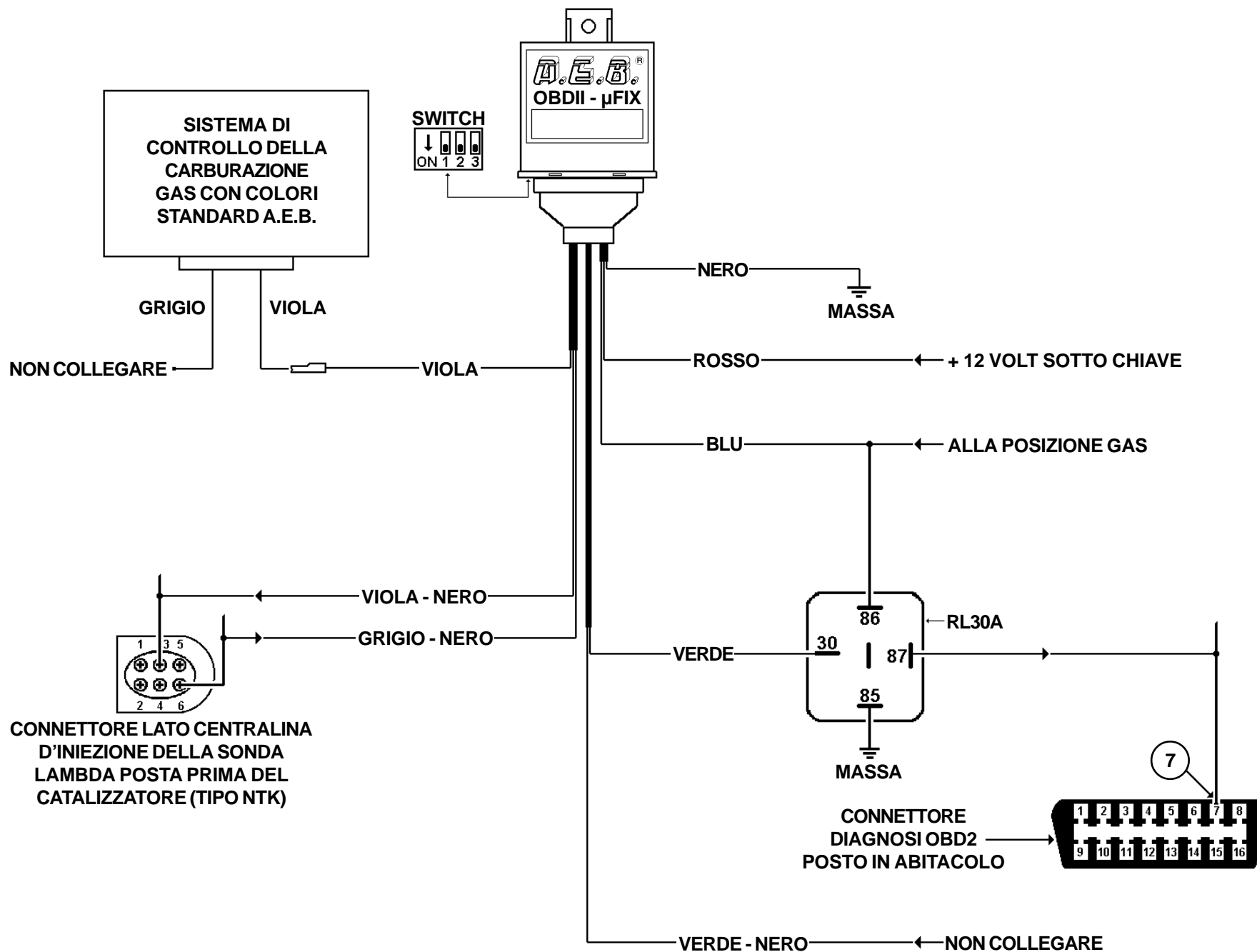

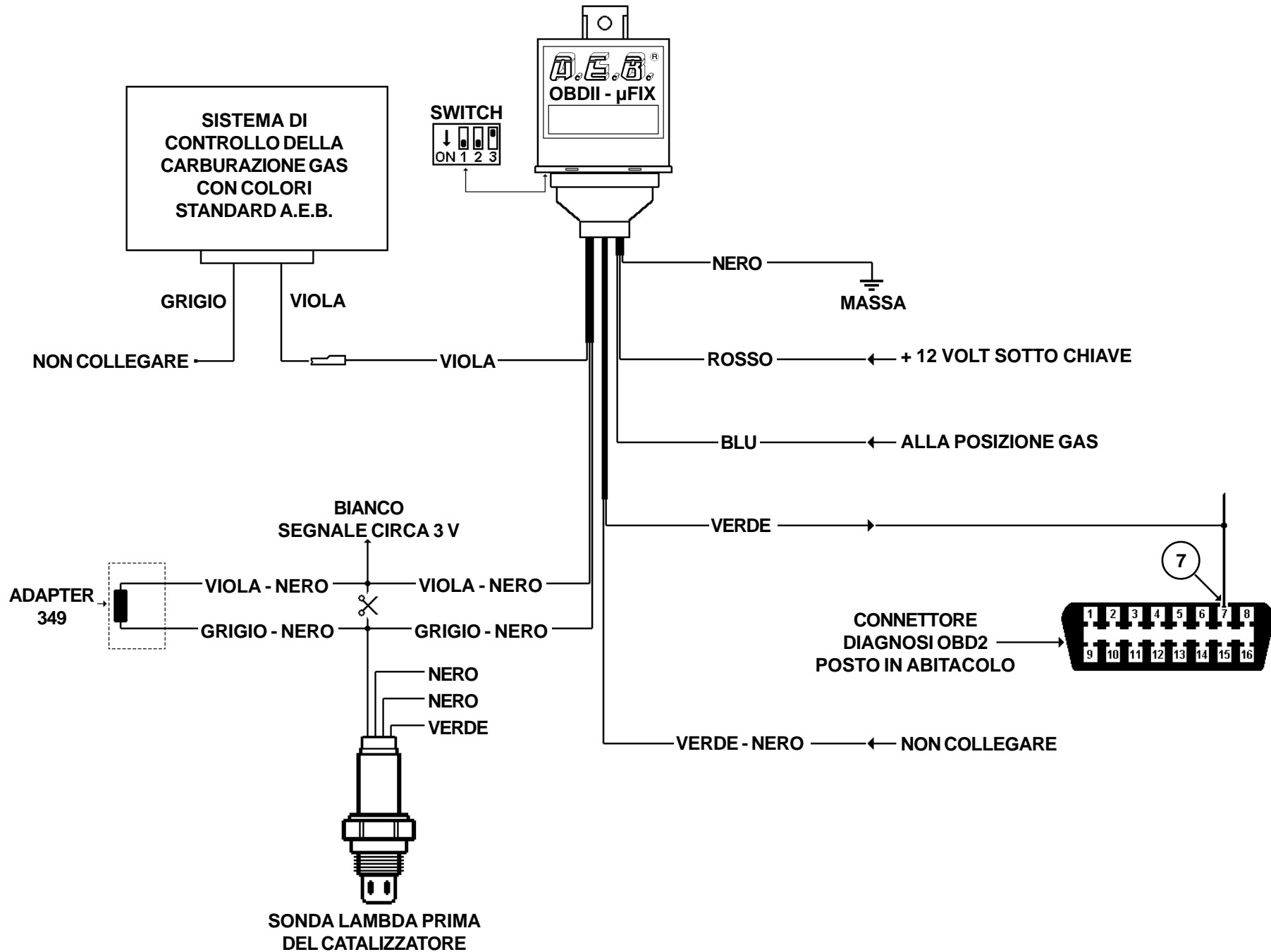

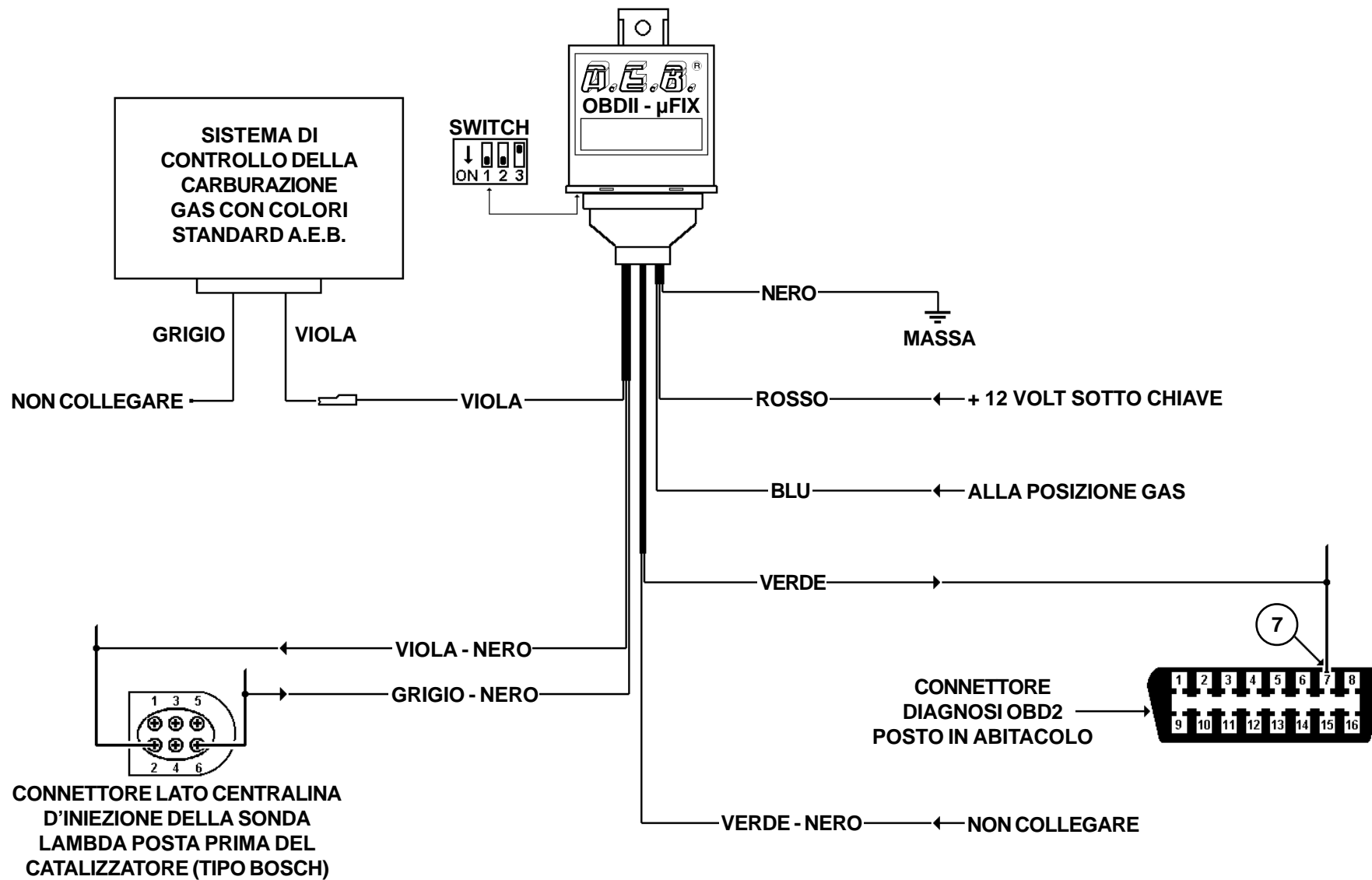

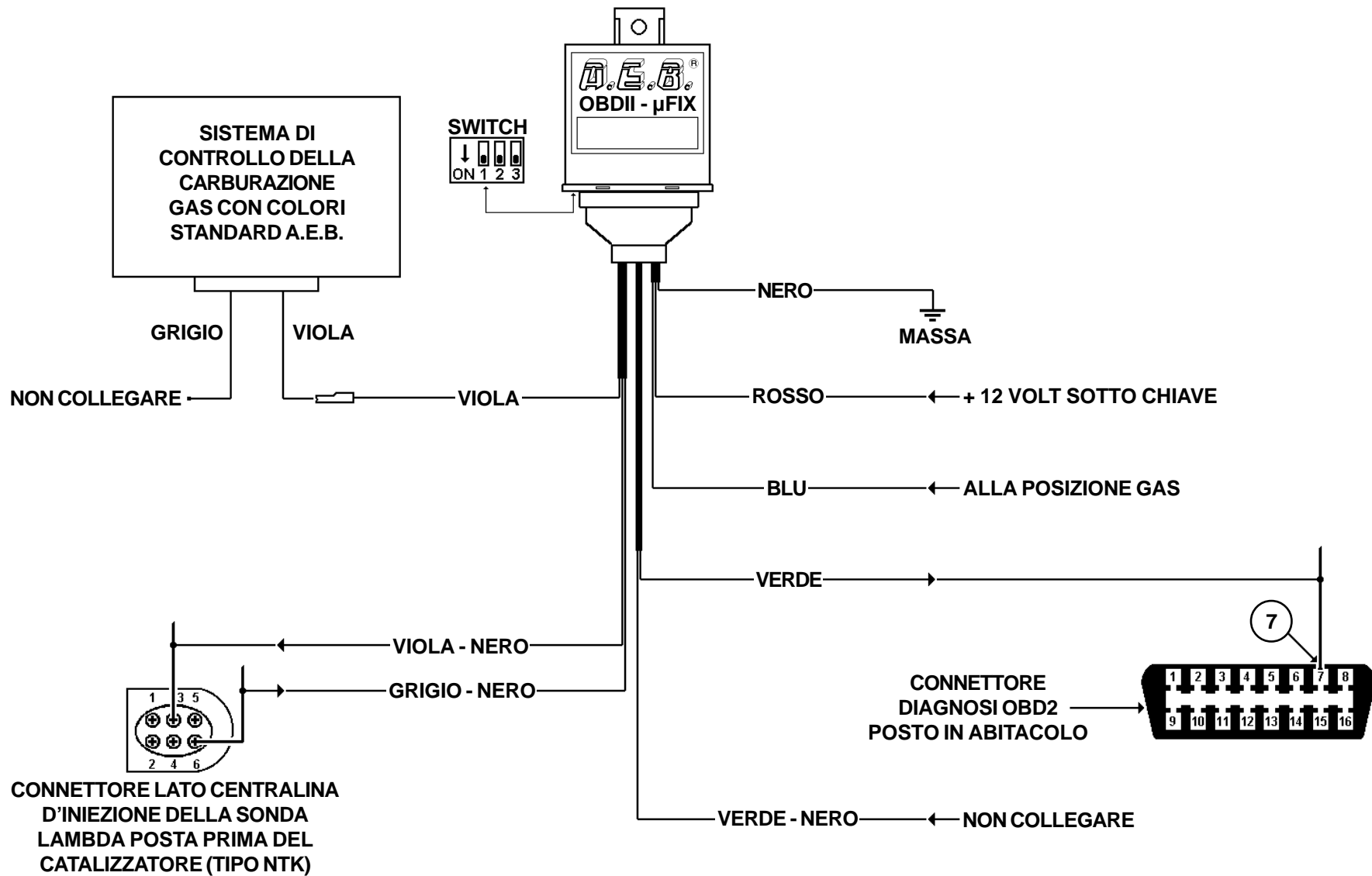

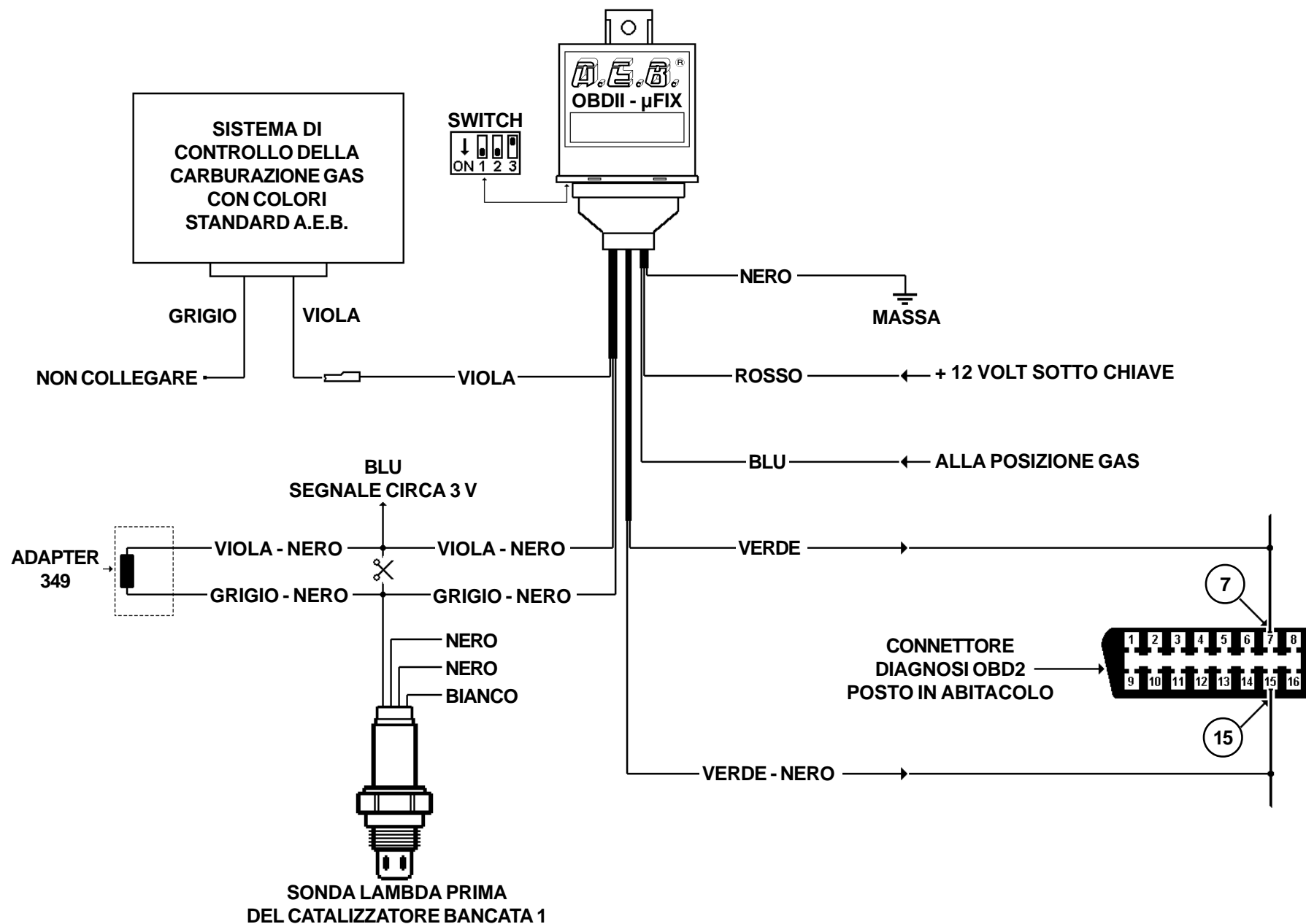

N.B.: LA BANCATA 1 È IN CORRISPONDENZA DEL CILINDRO 1



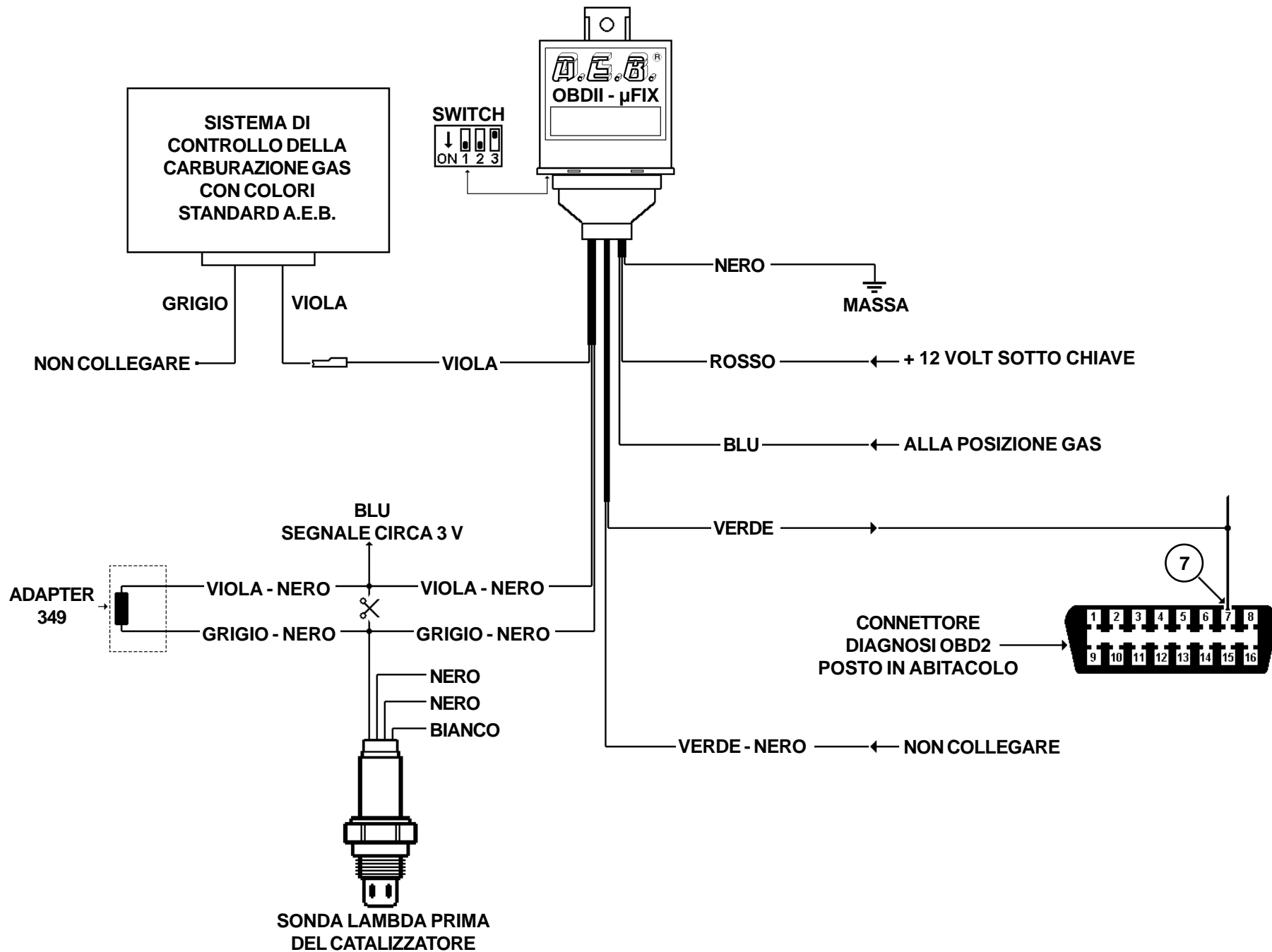

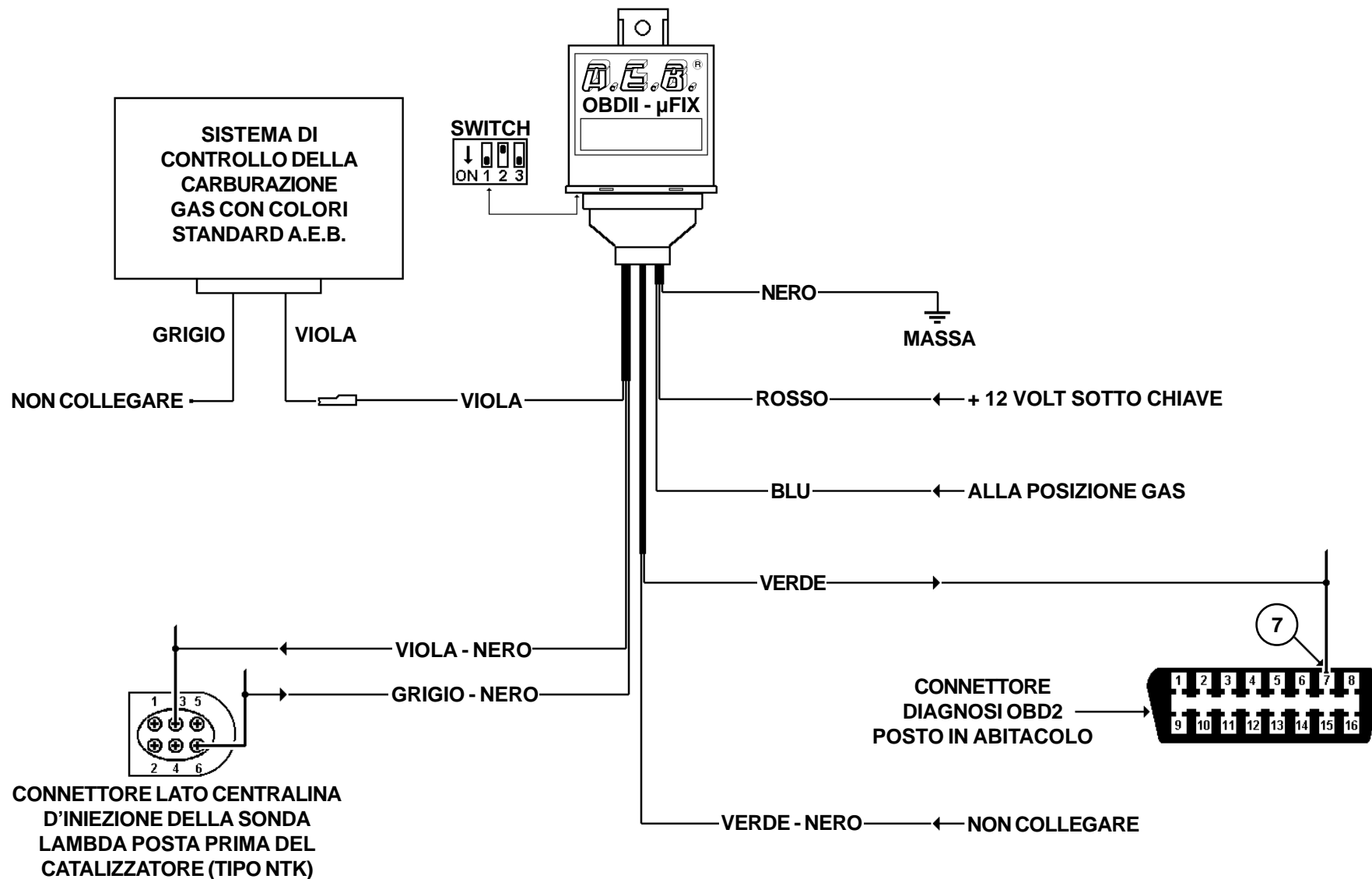

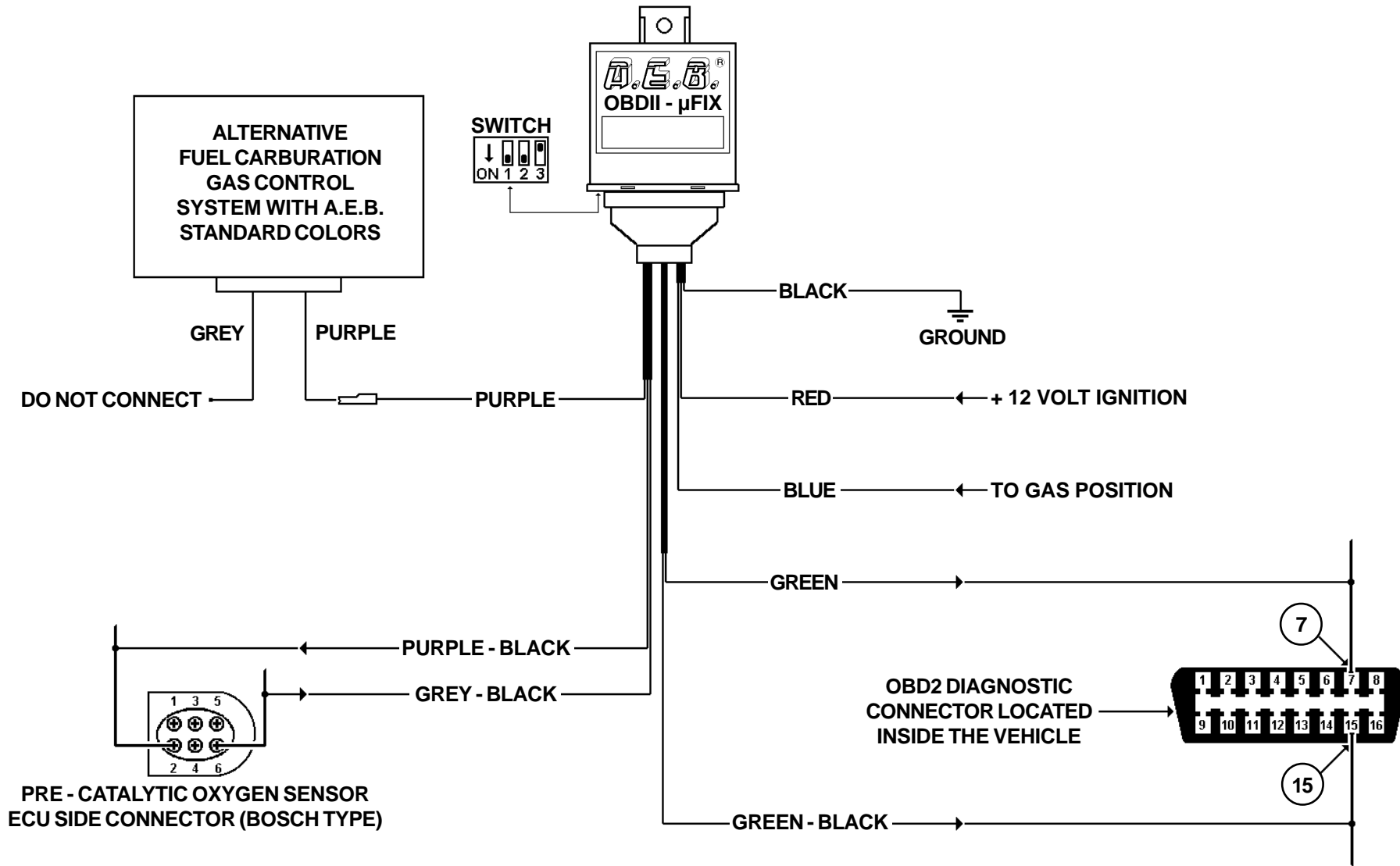

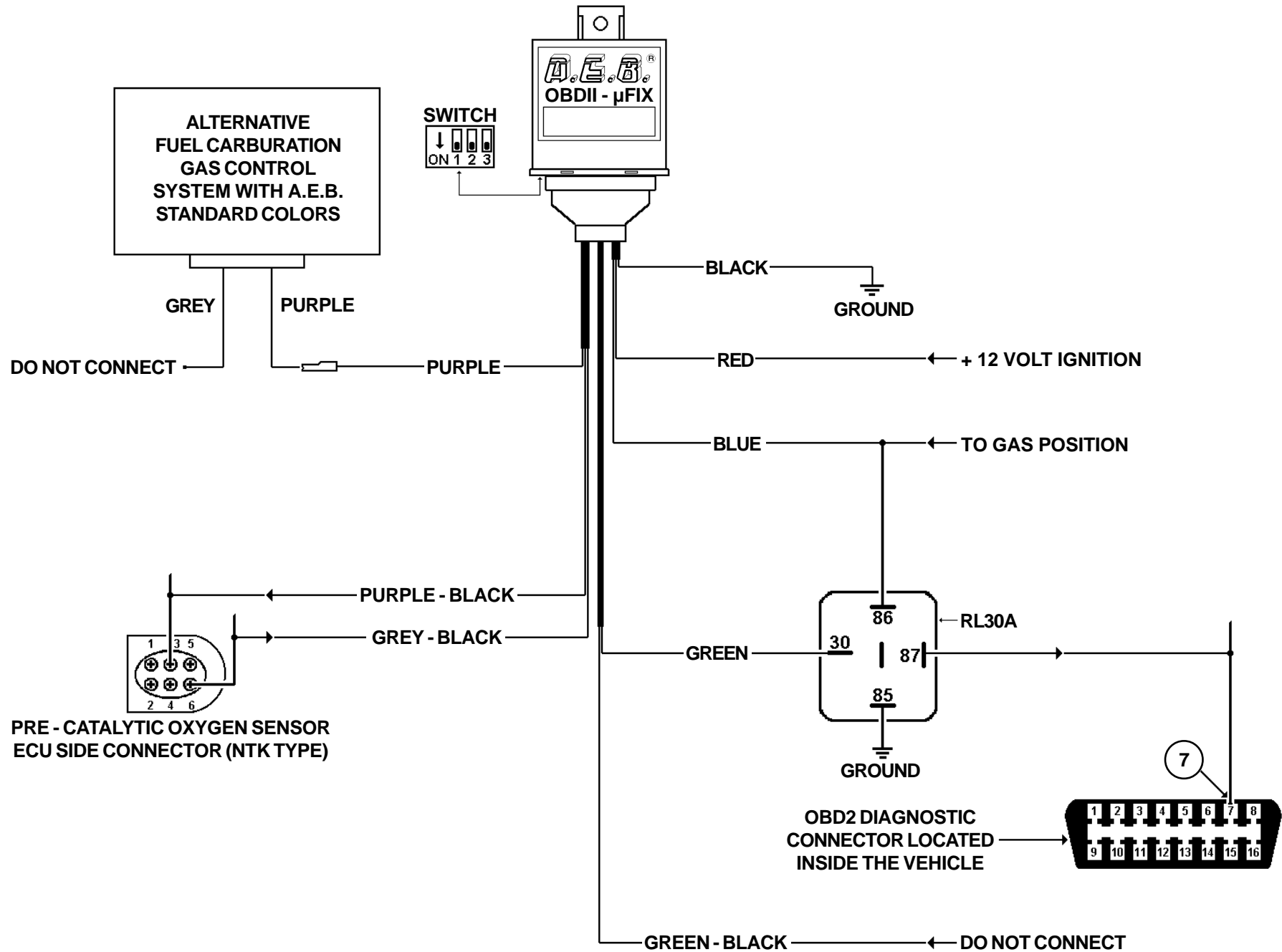

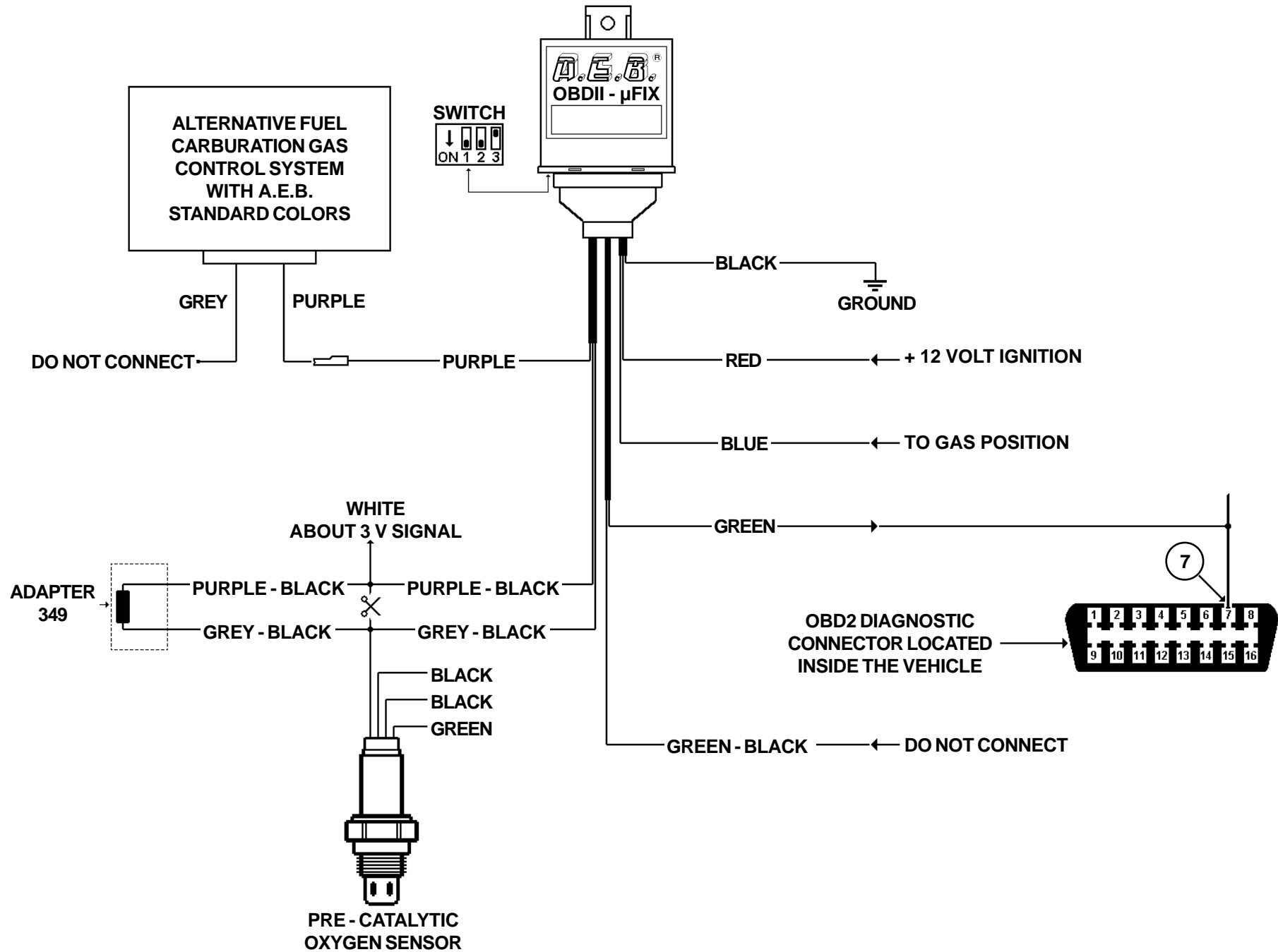

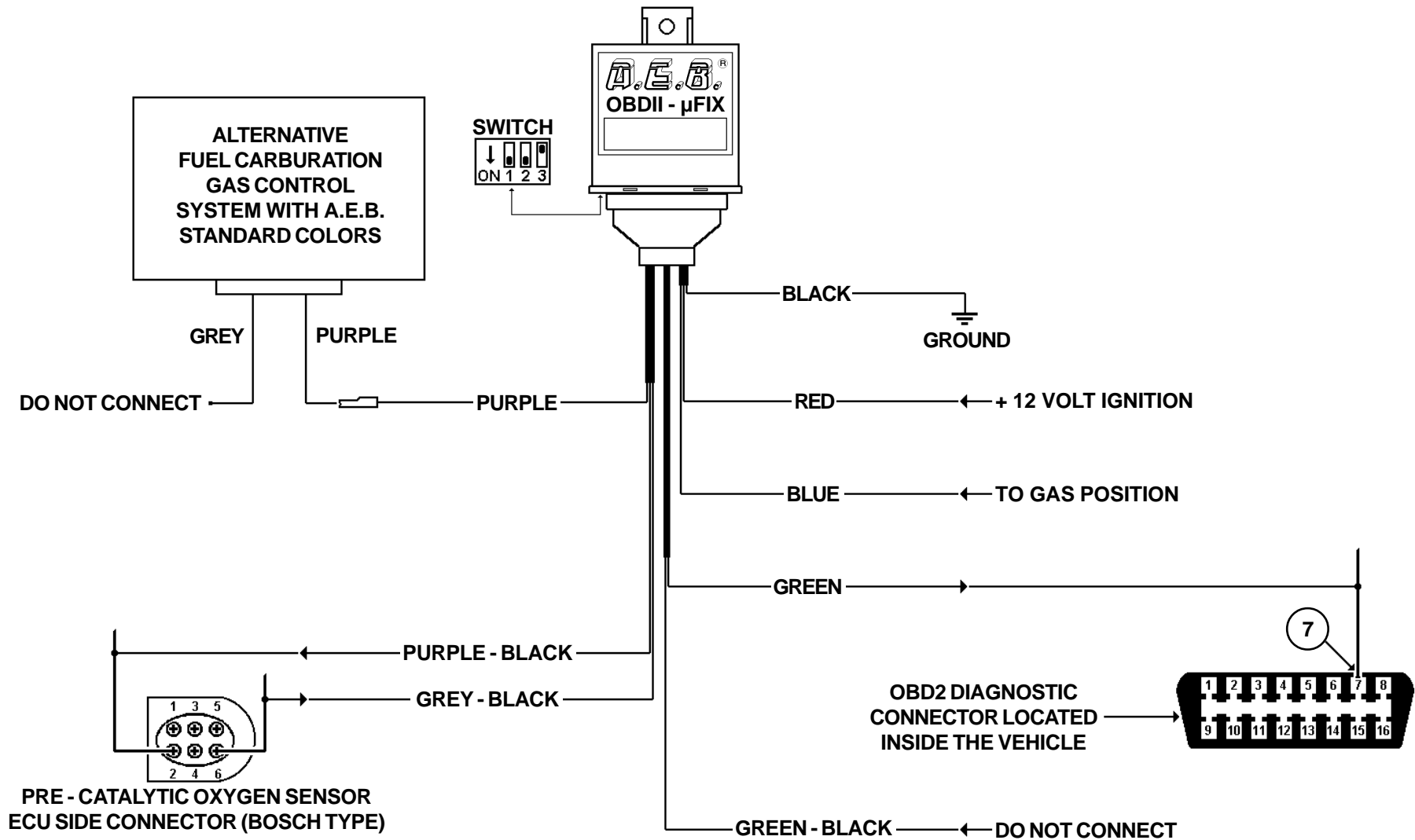

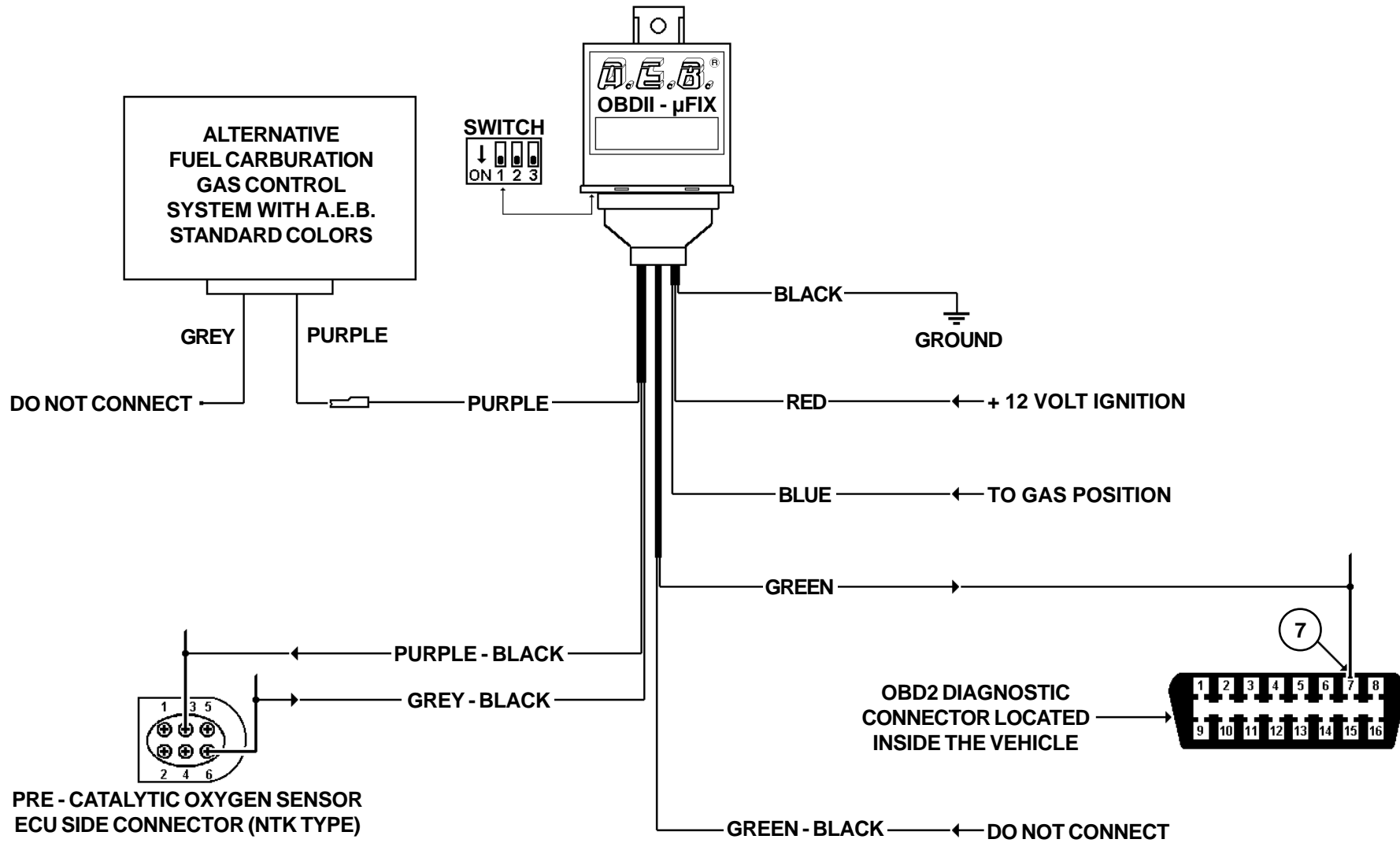

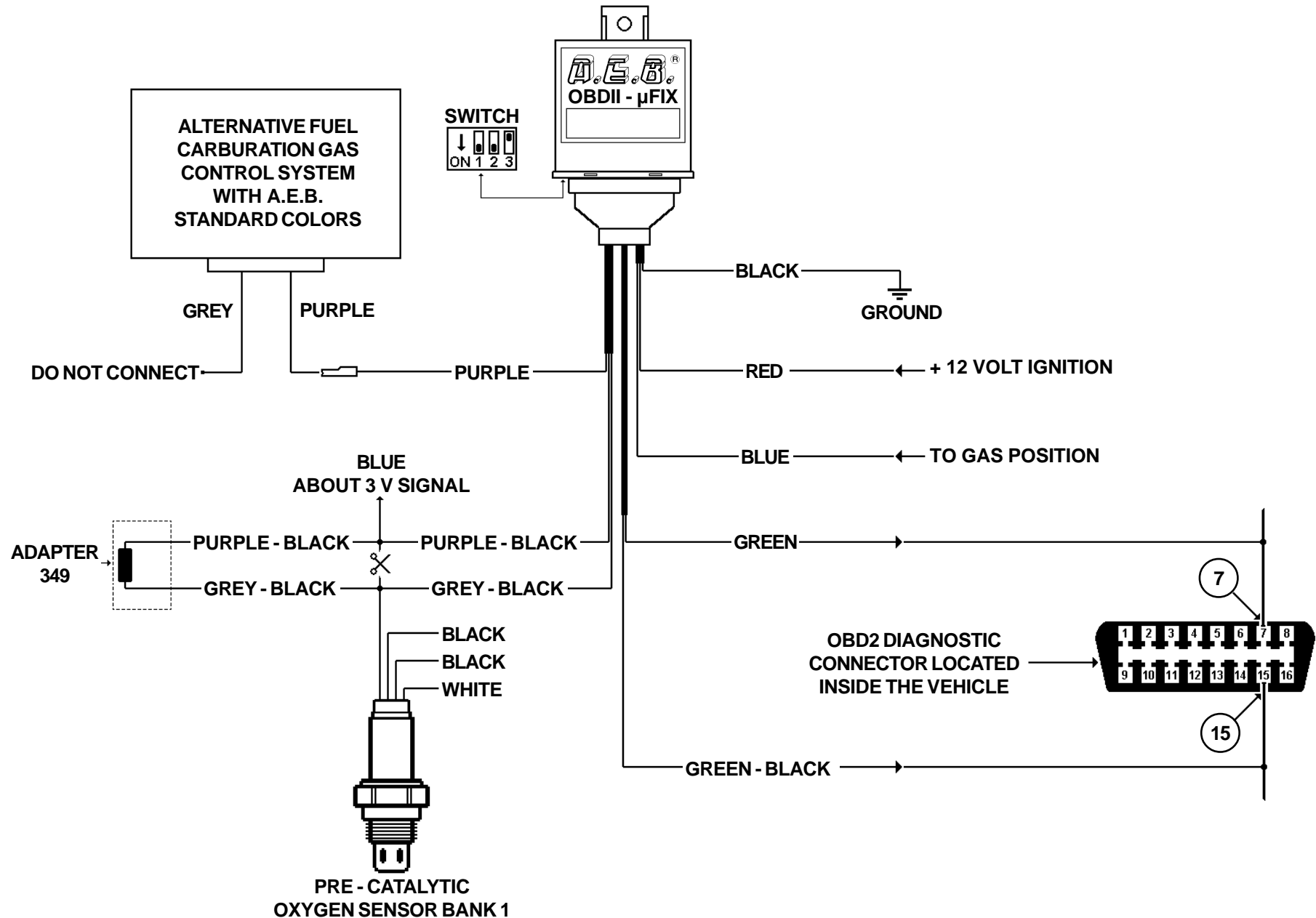

NOTE: THE BANK 1 CORRESPONDE TO CYLINDER 1



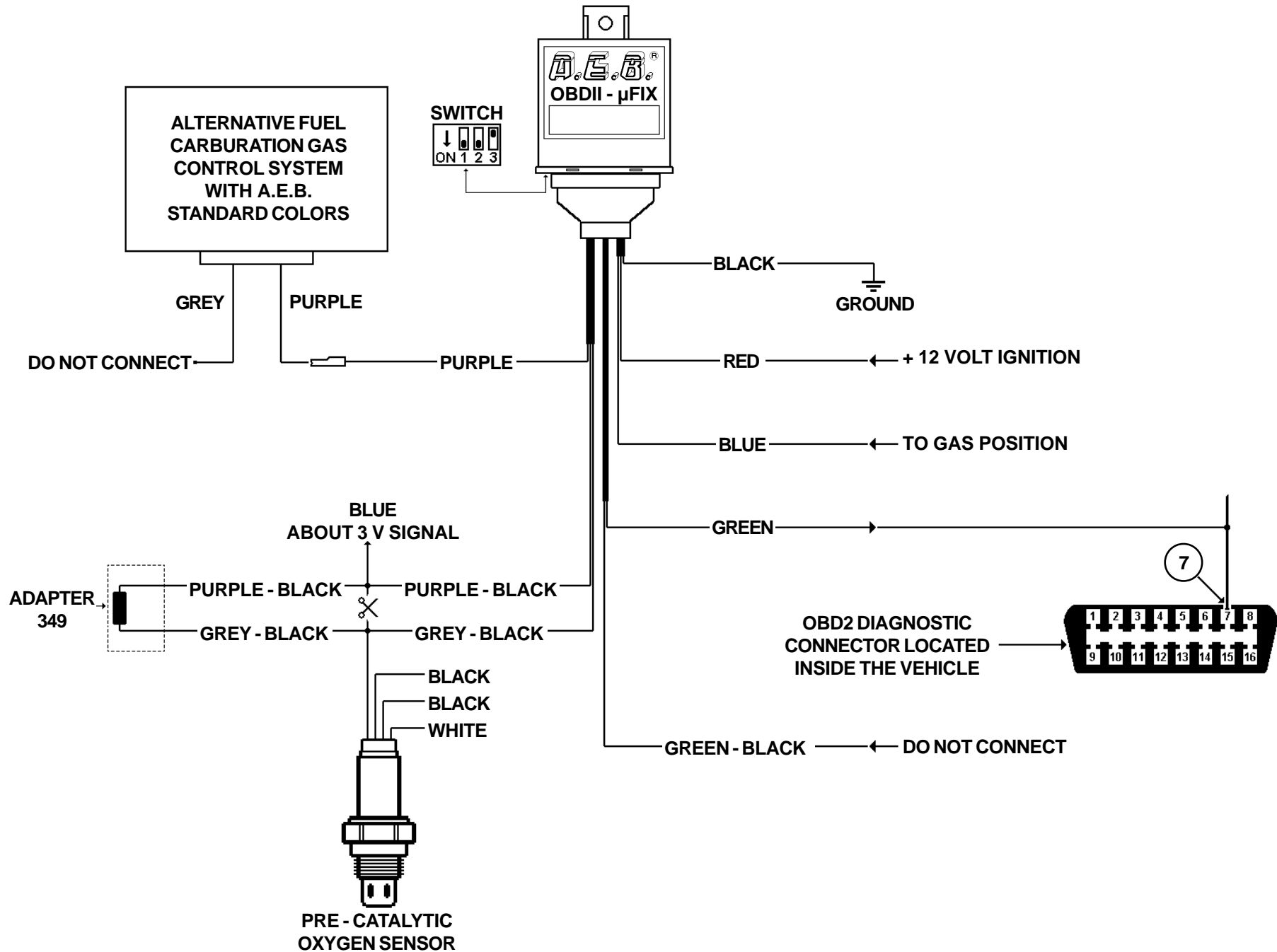

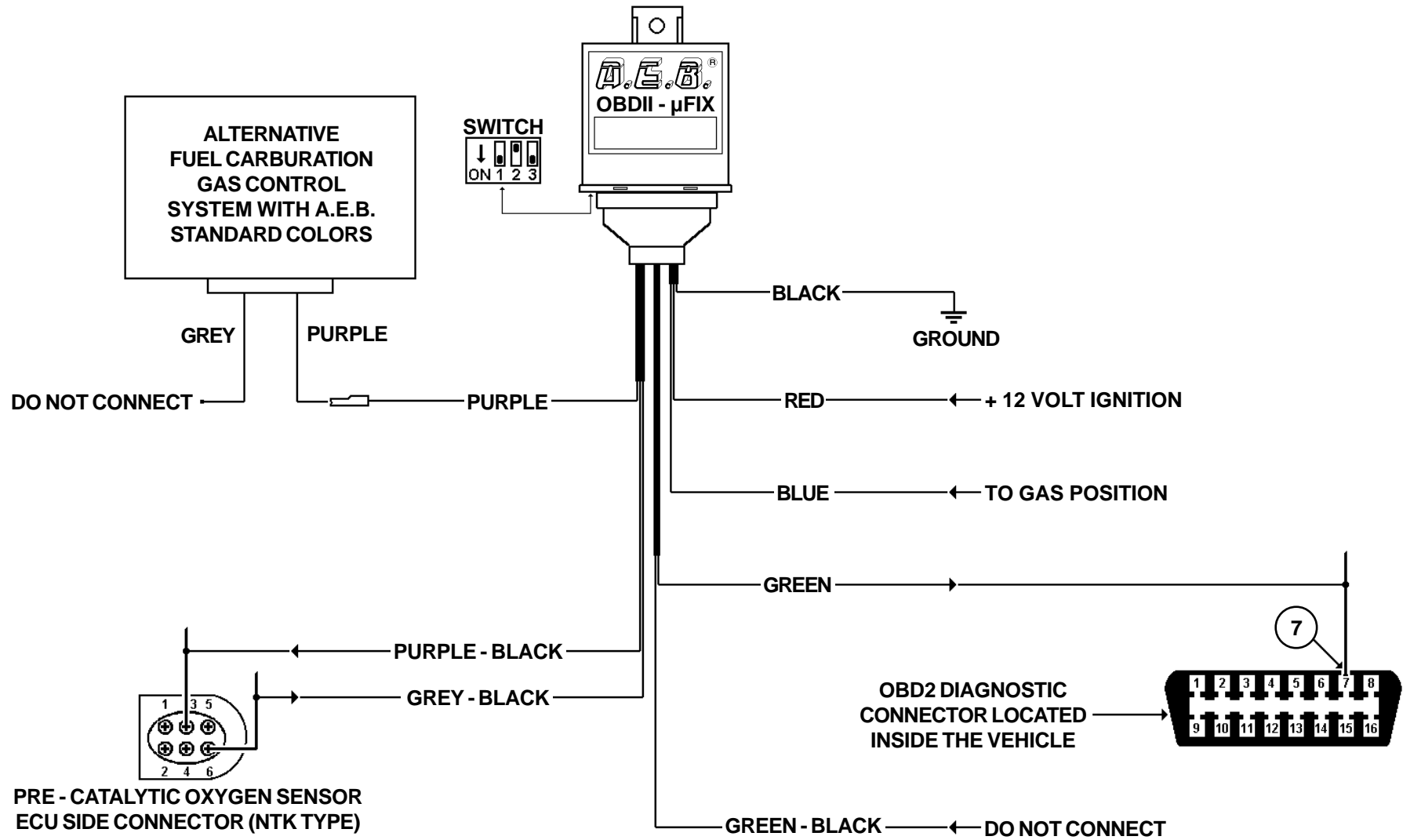

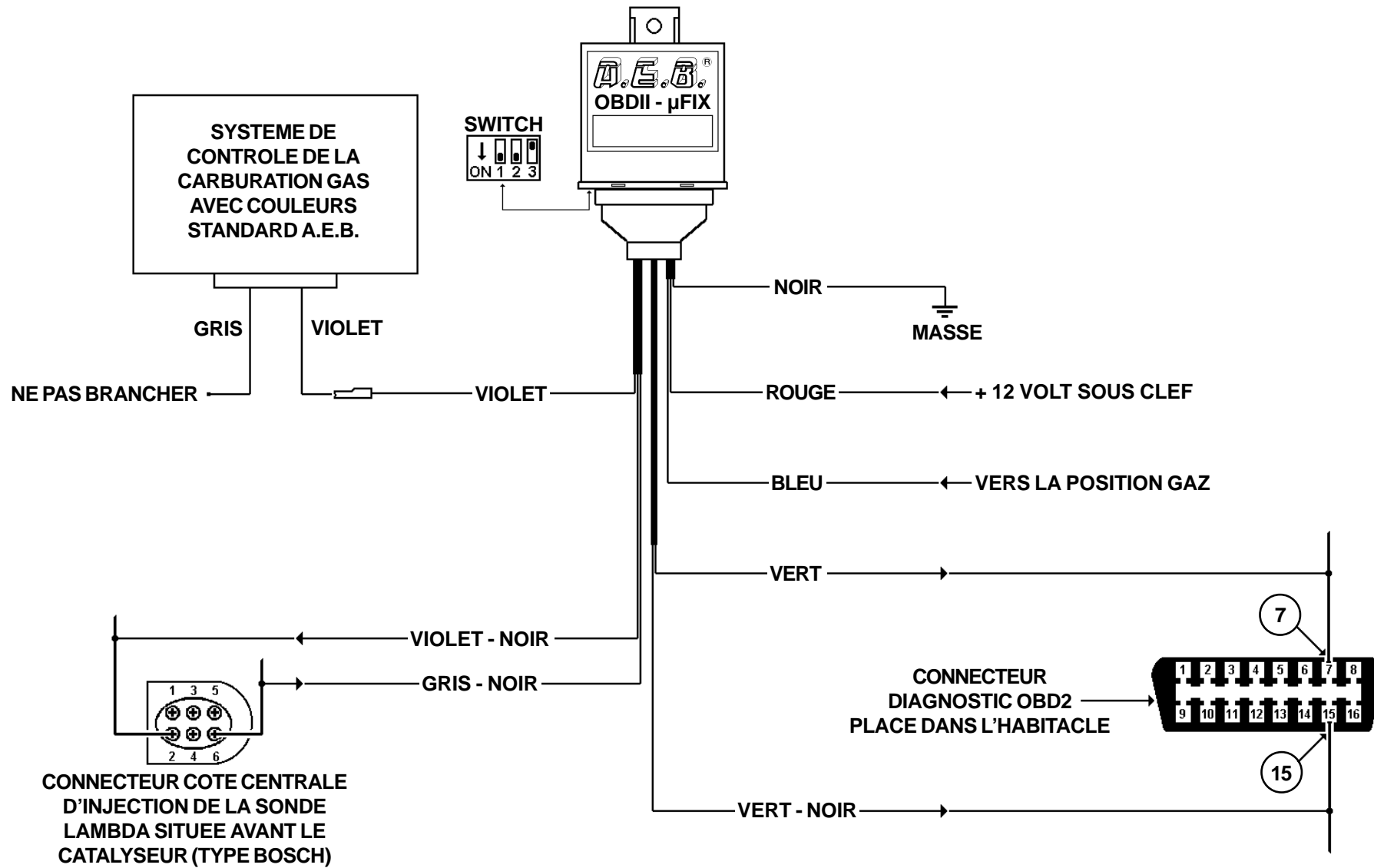

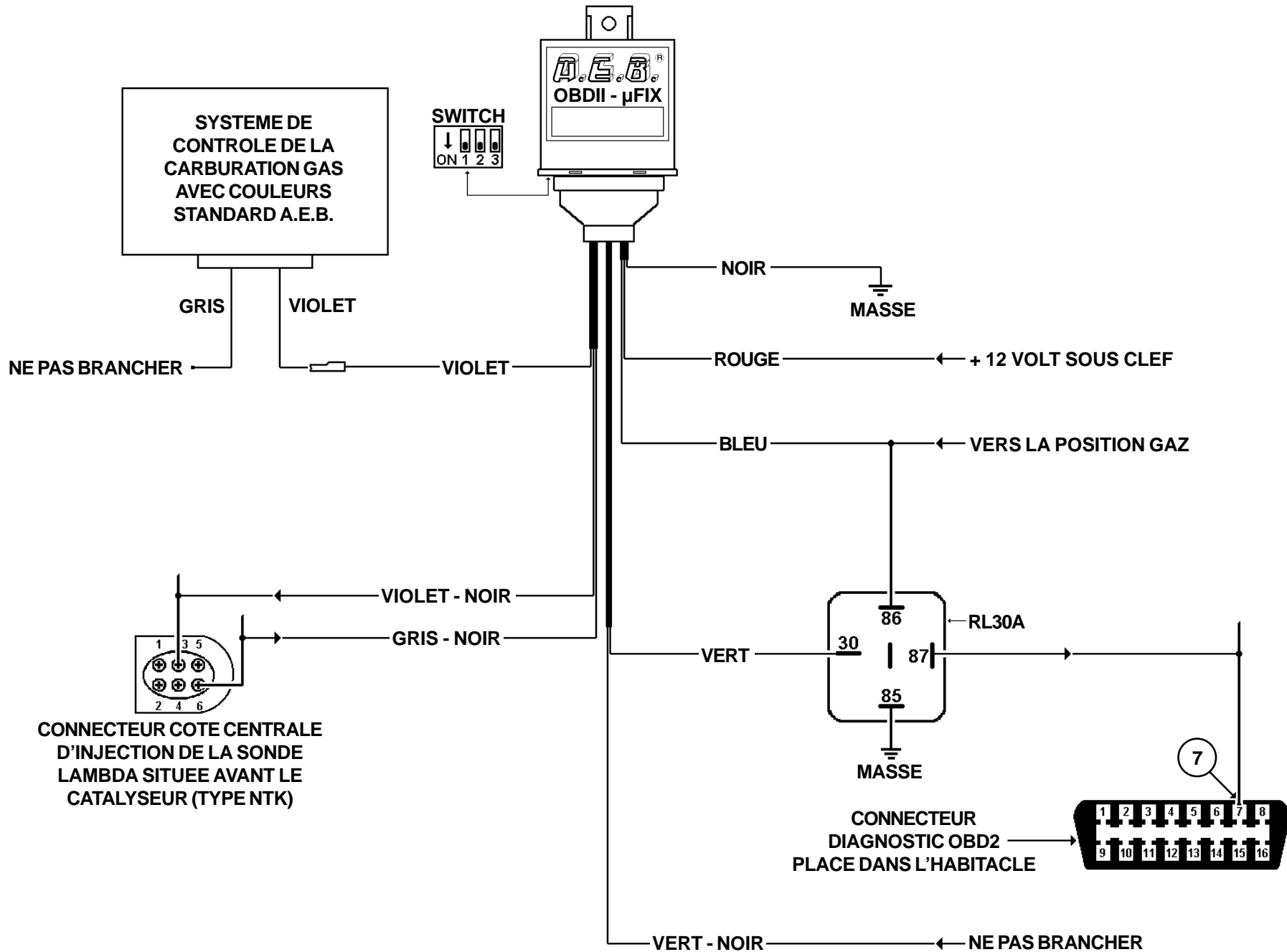

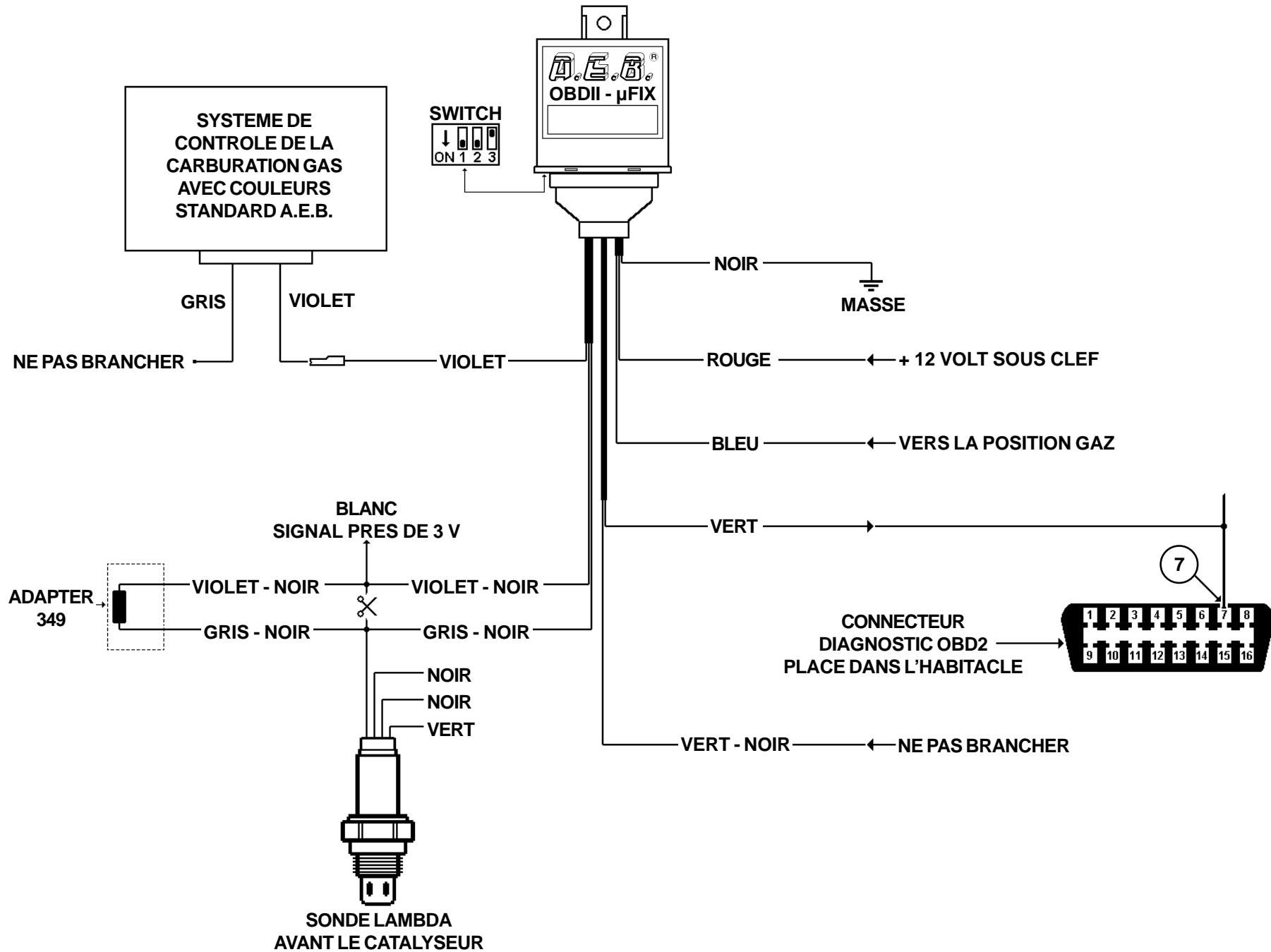

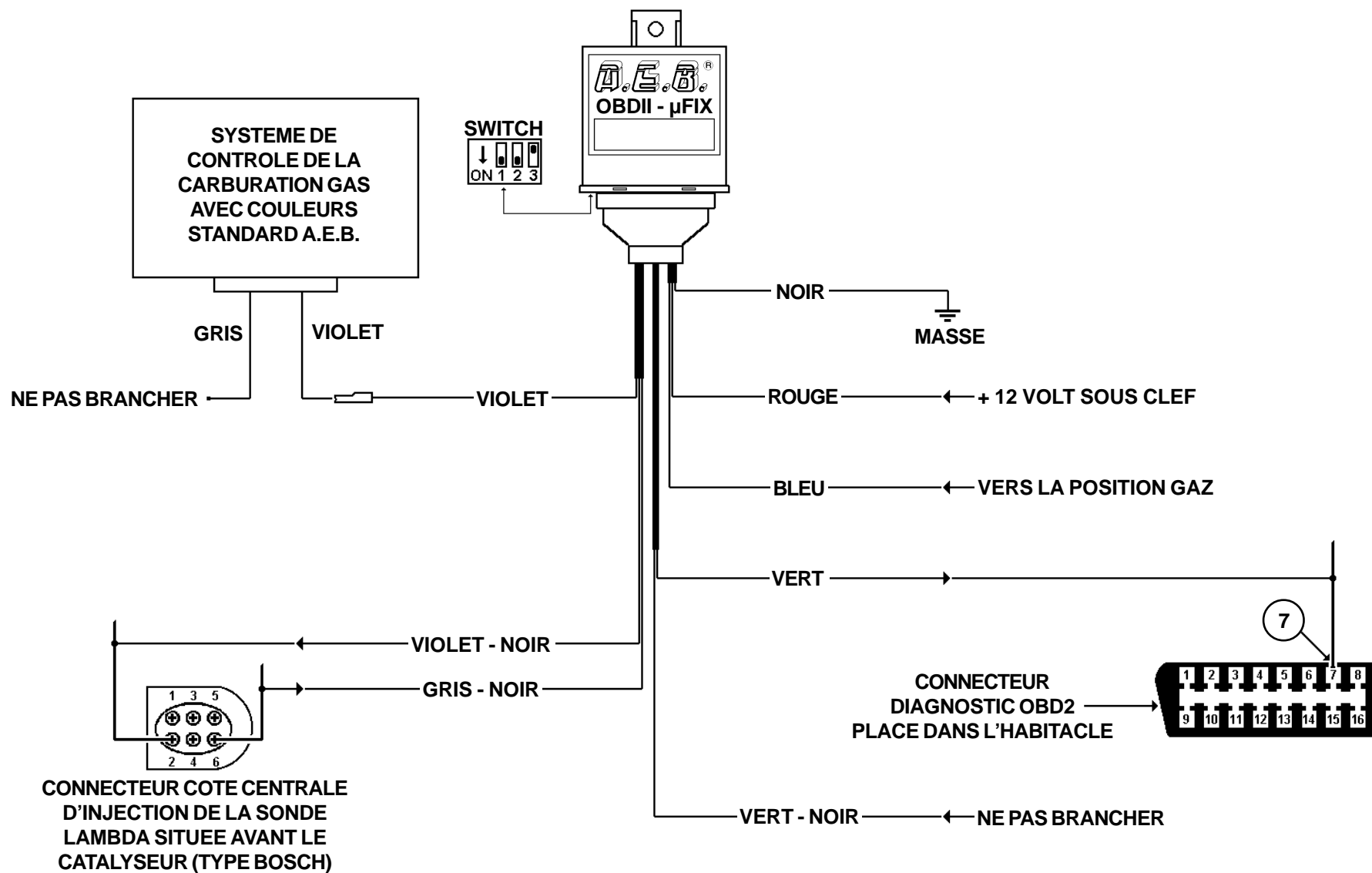

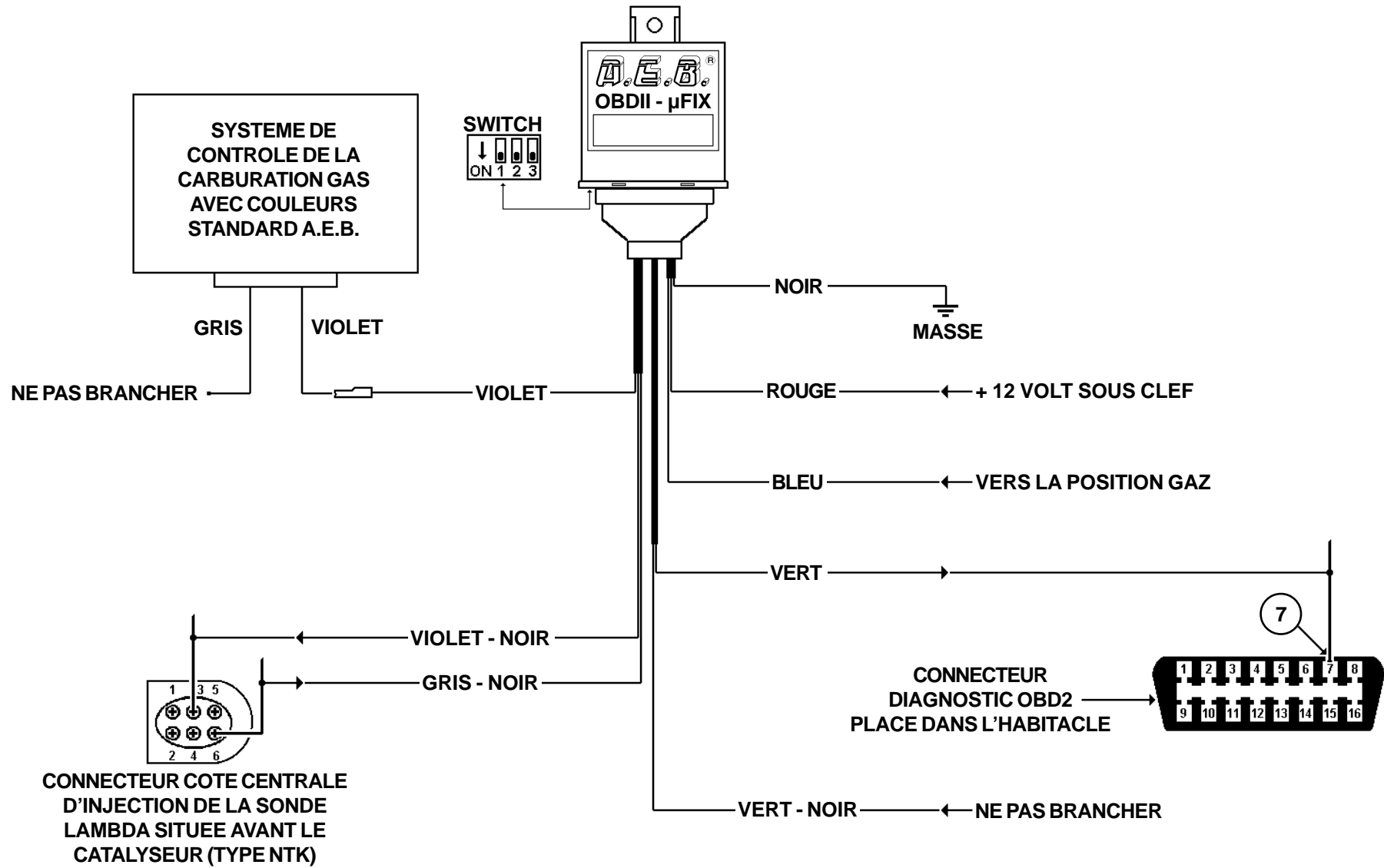

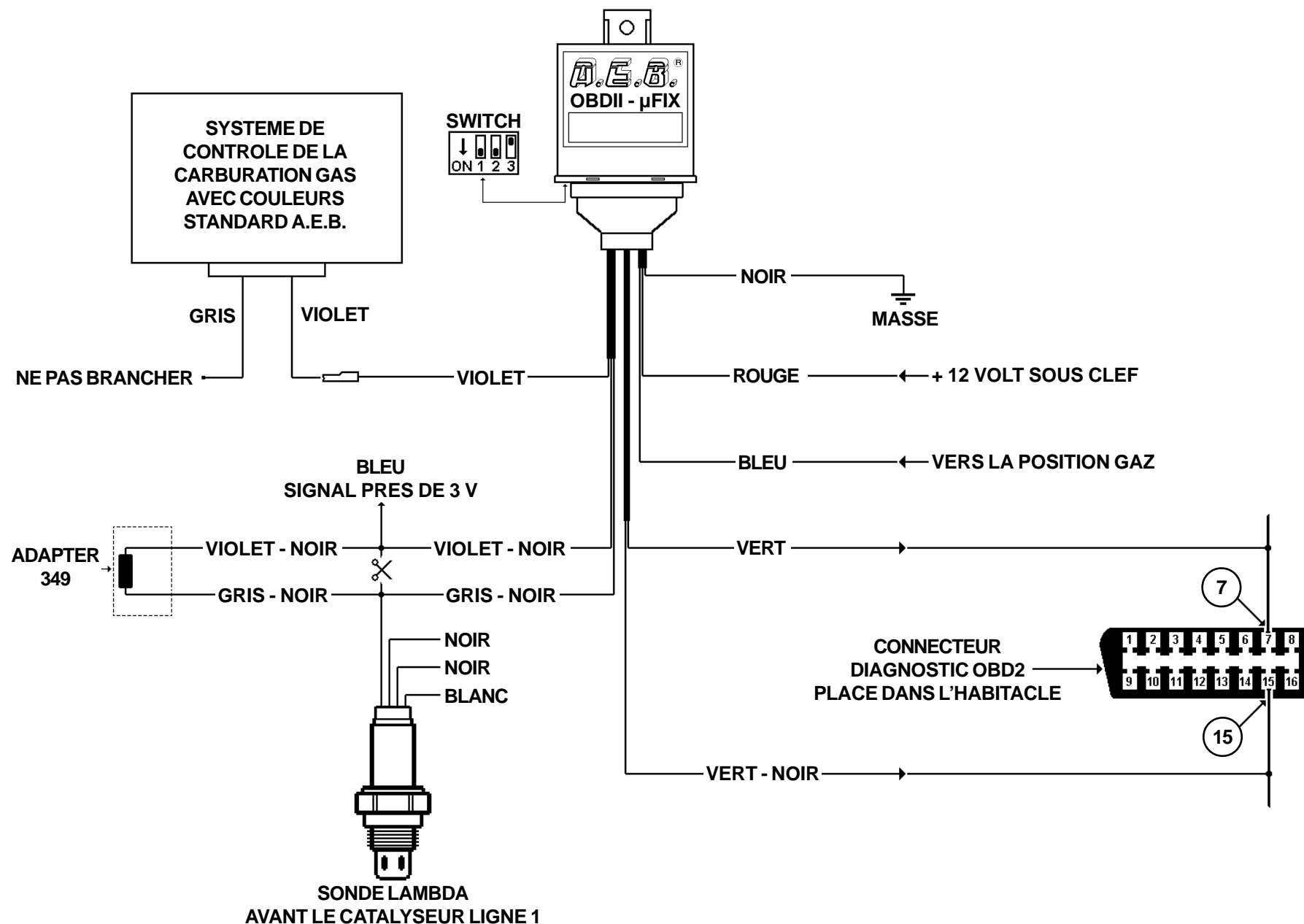

NOTE: LA LIGNE 1 CORRESPOND AU CYLINDRE 1



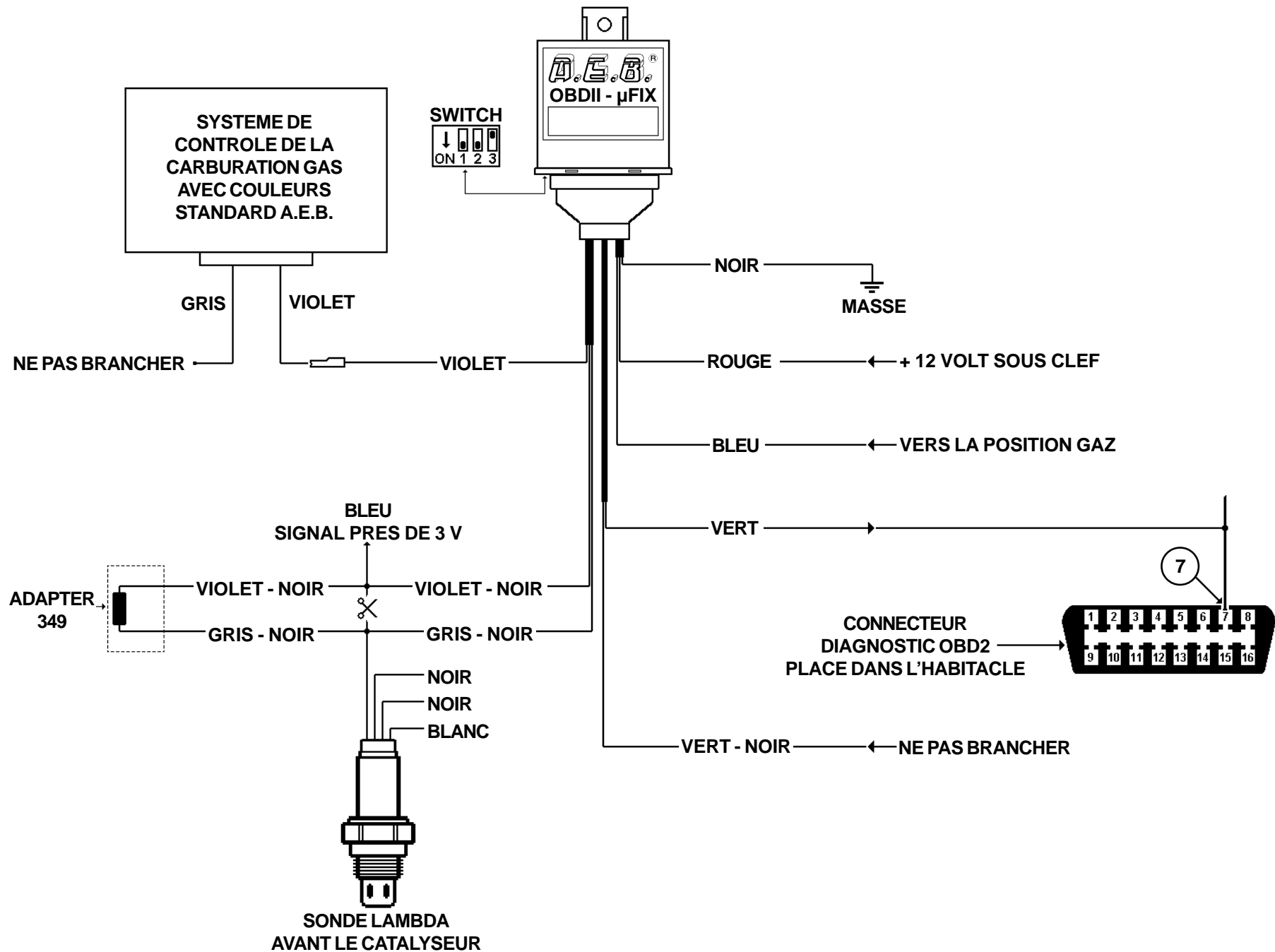

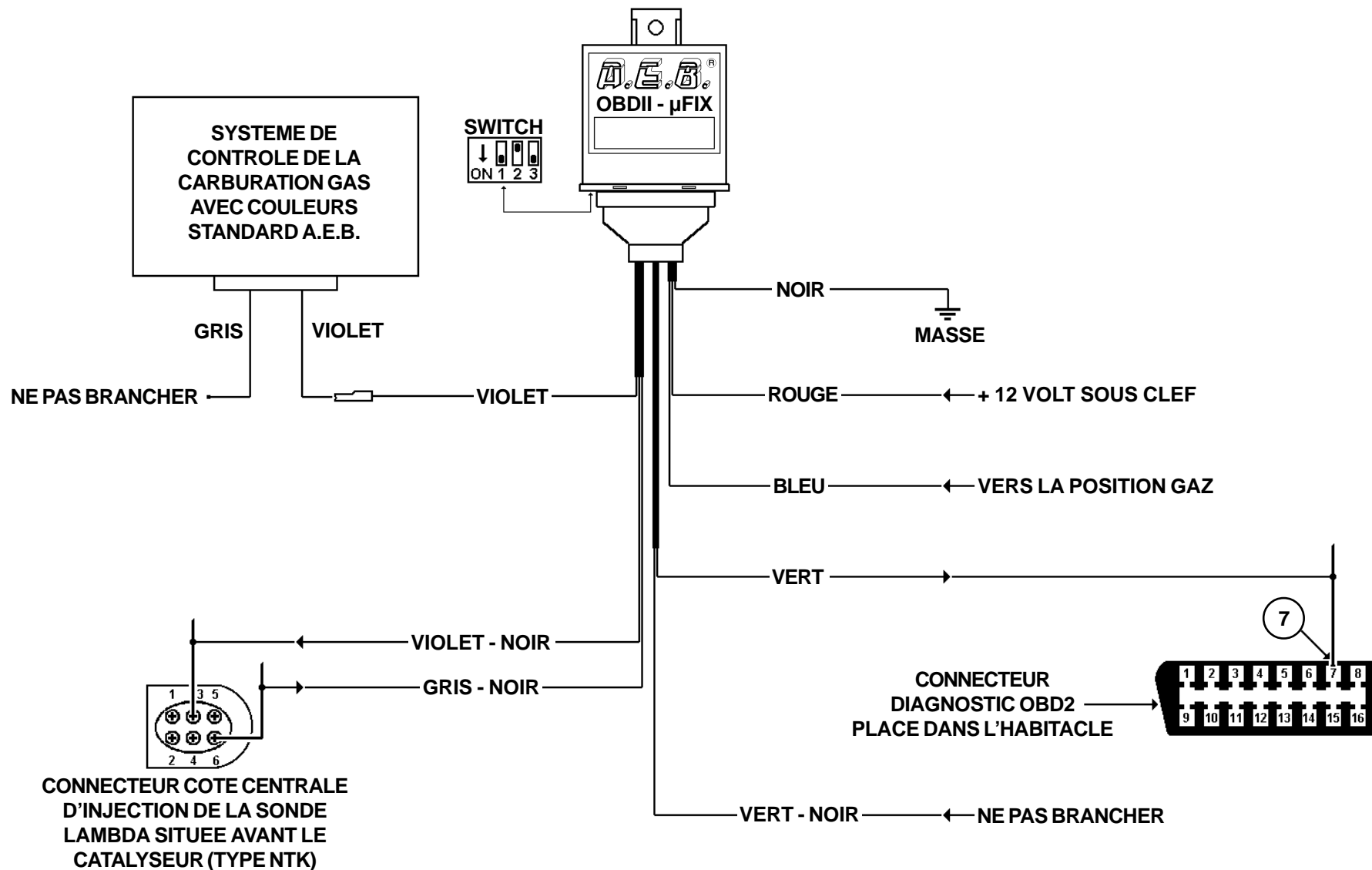

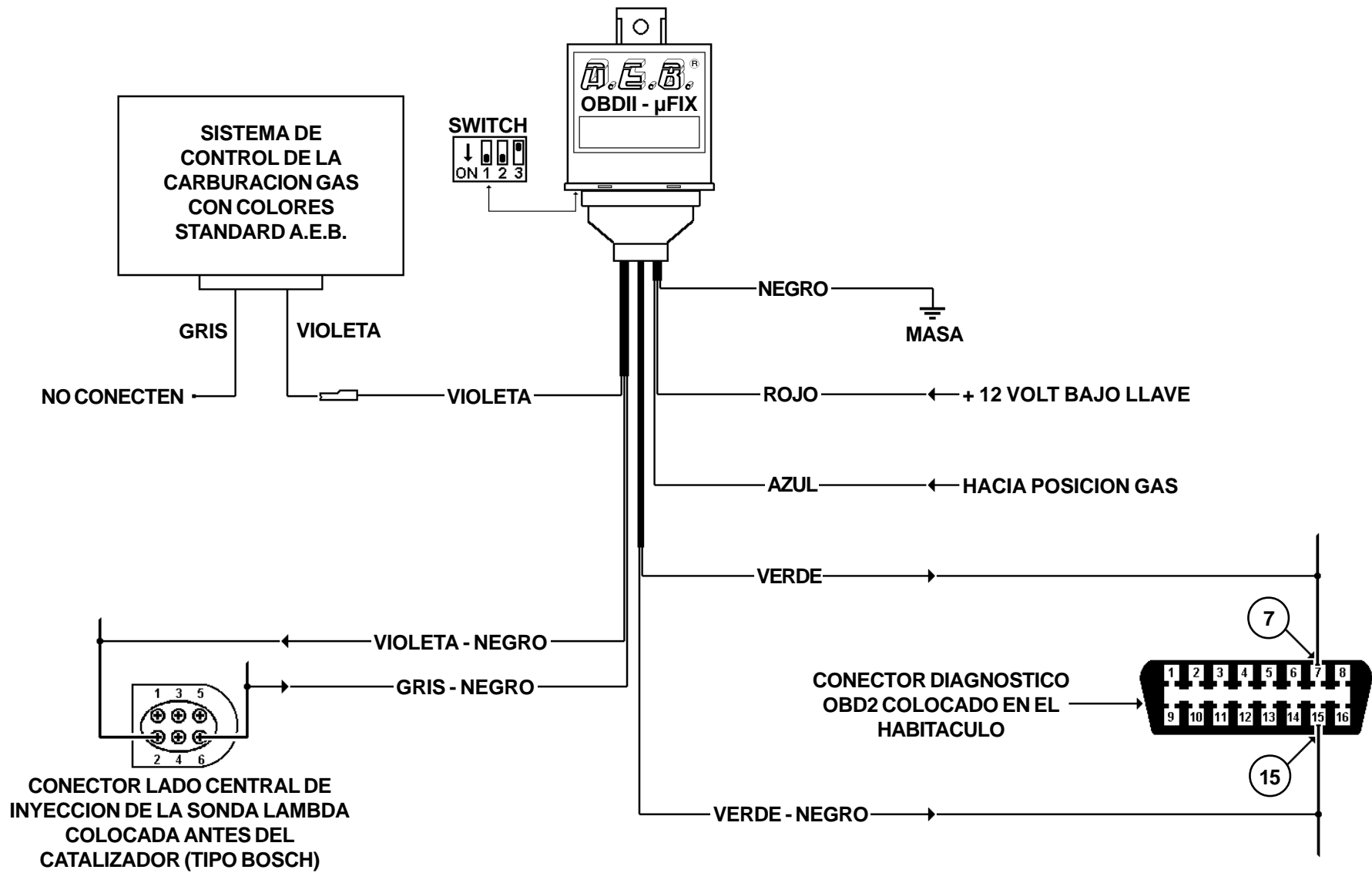

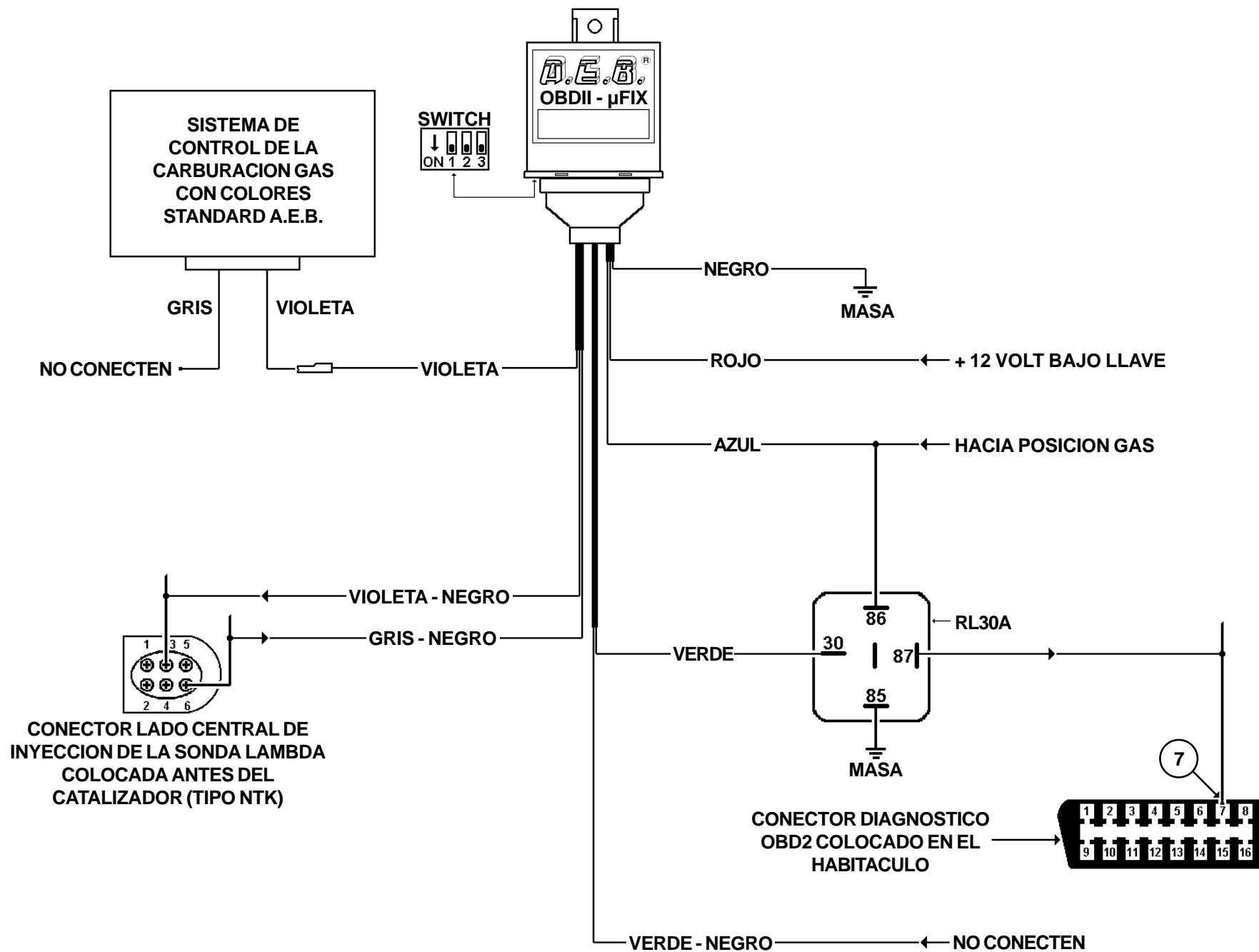

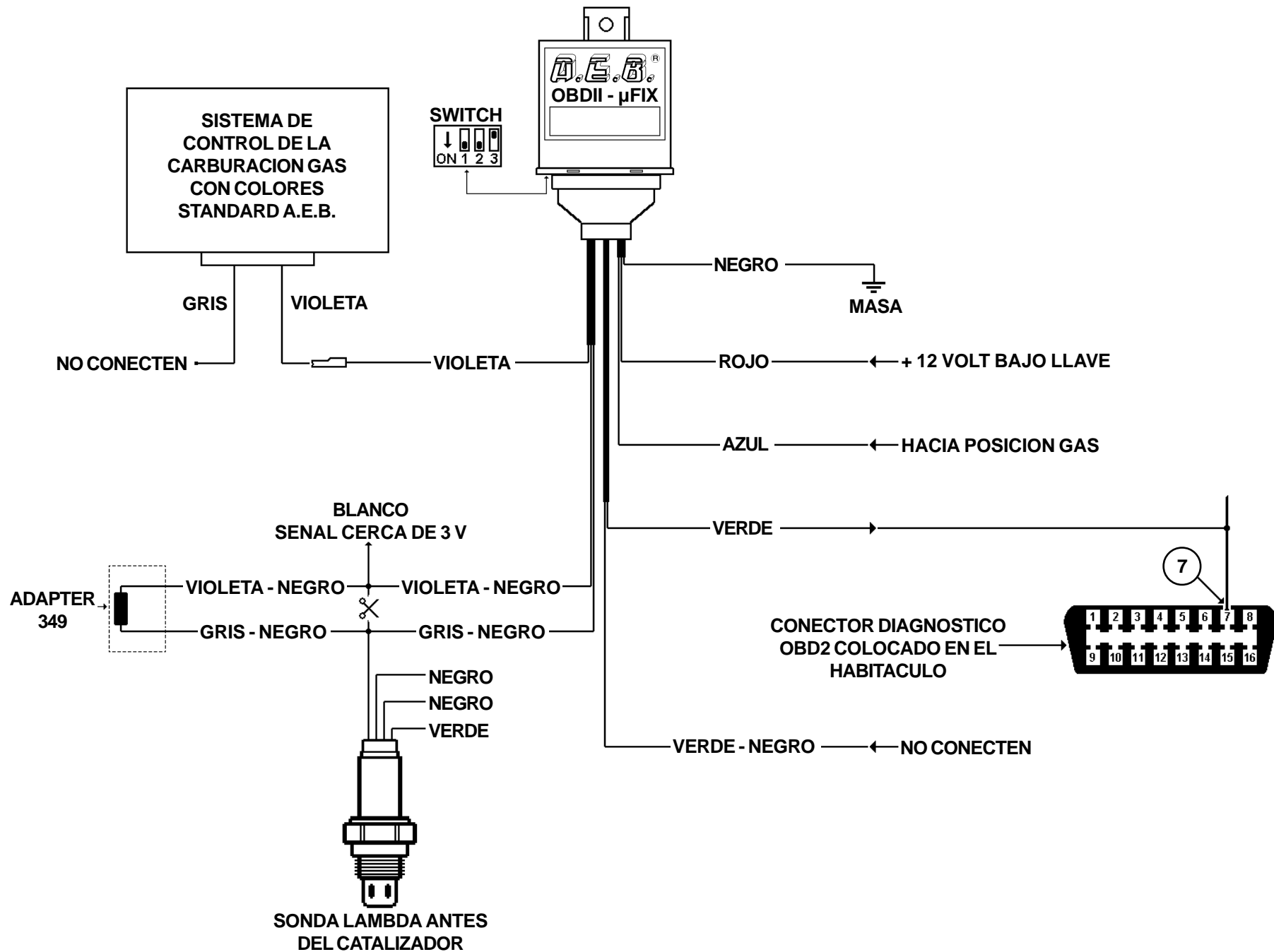

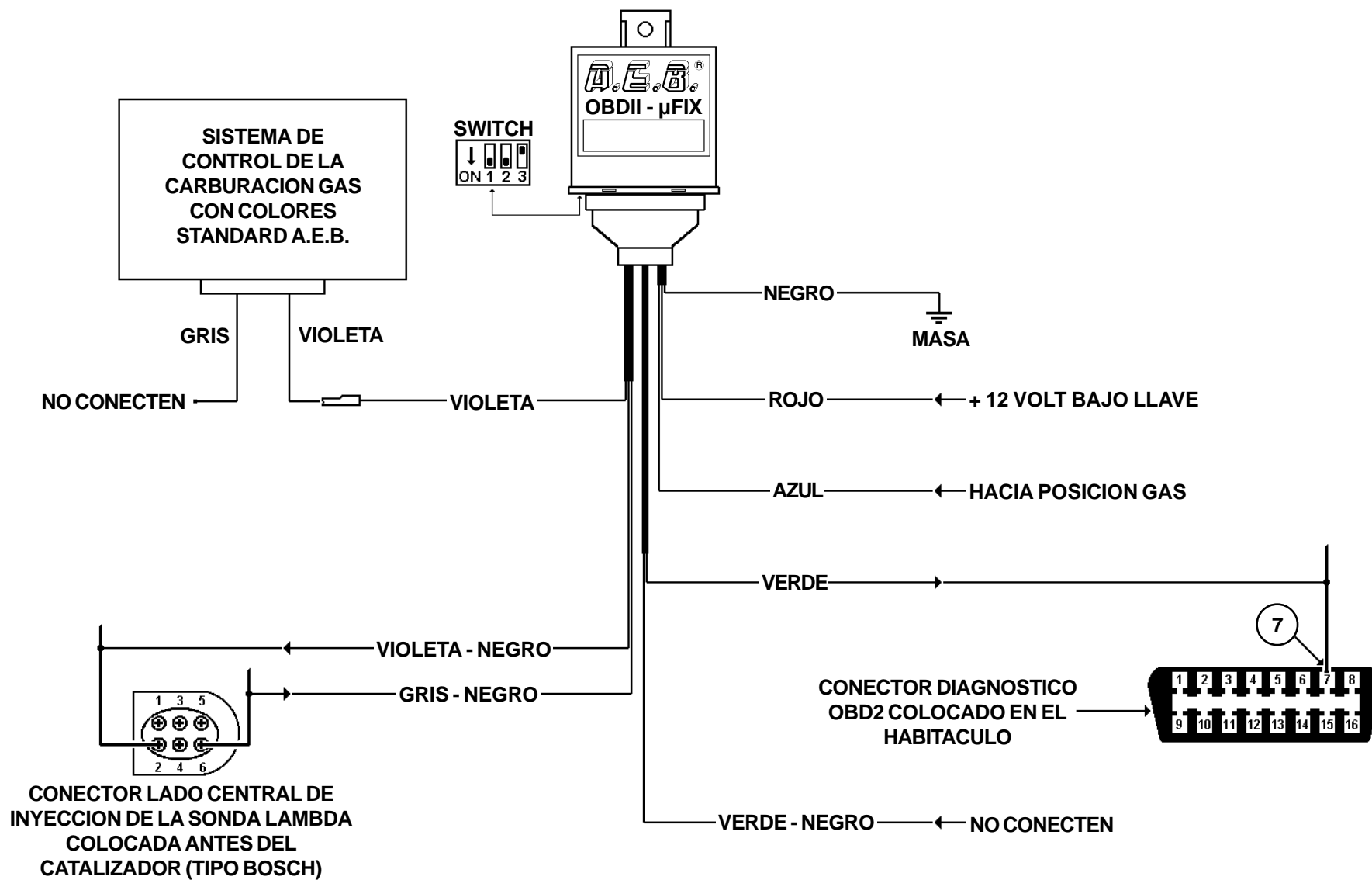

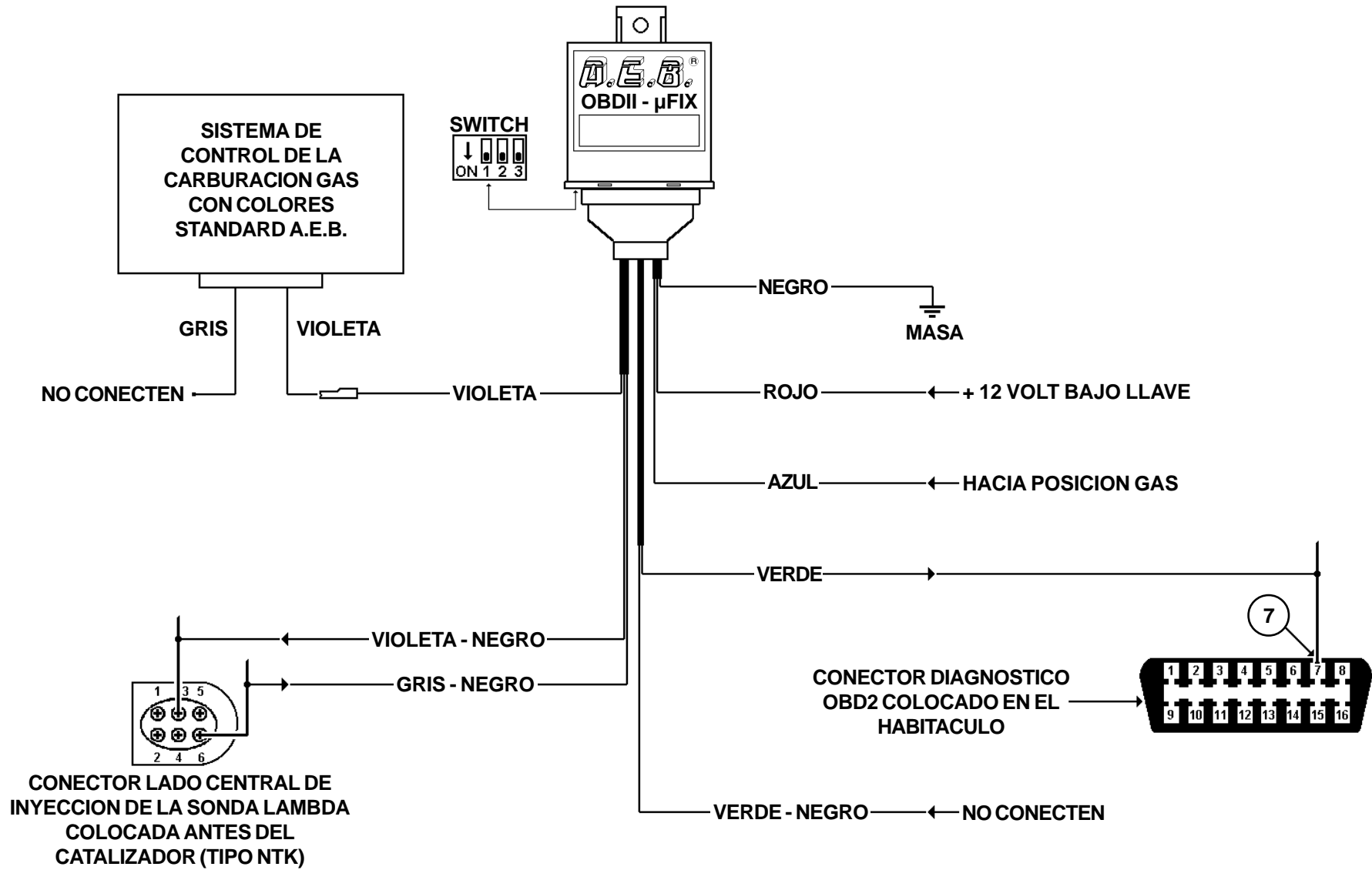

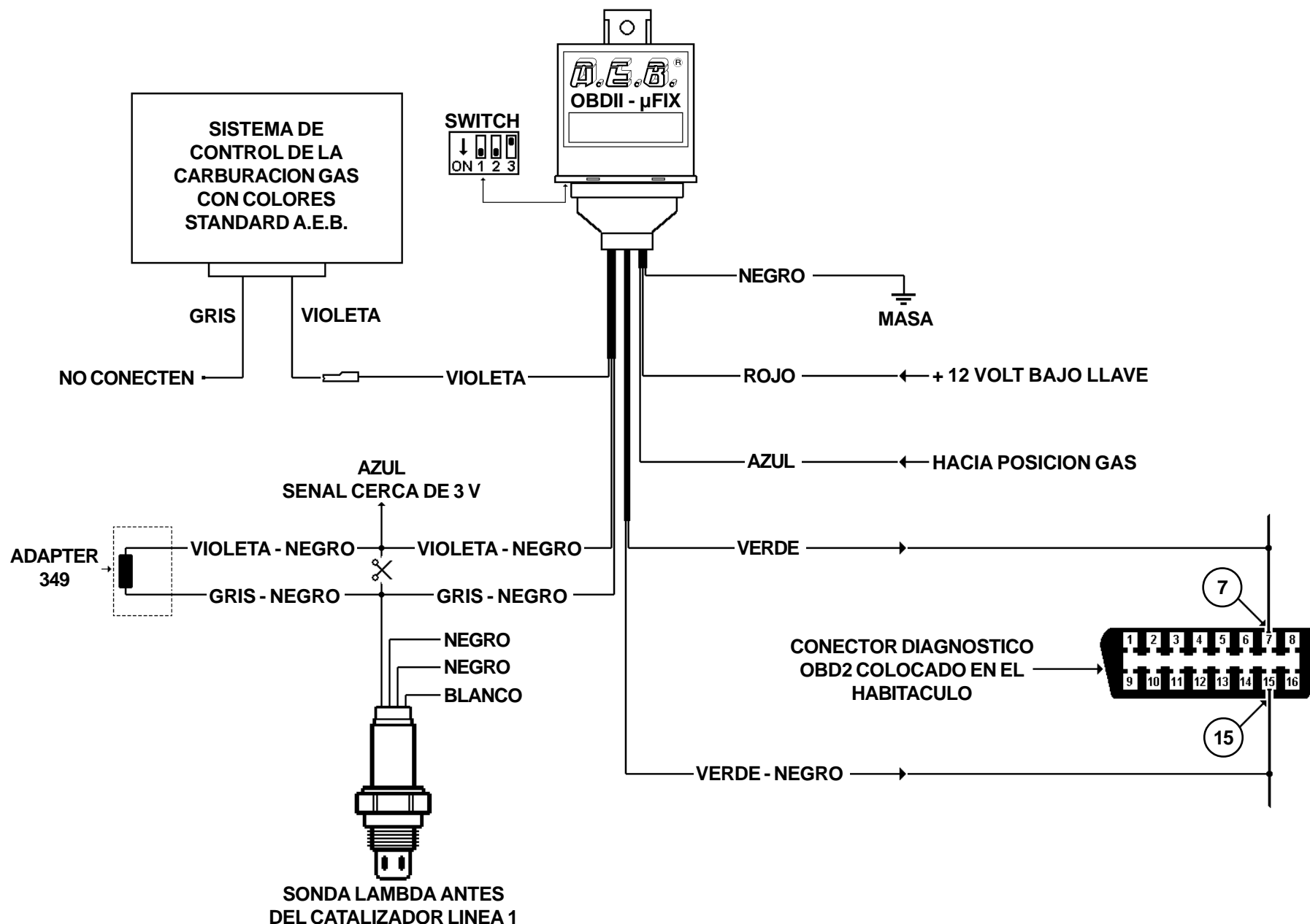

NOTA: LA LINEA 1 SE ENCUENTRA EN CORRESPONDENCIA DEL CILINDRO 1



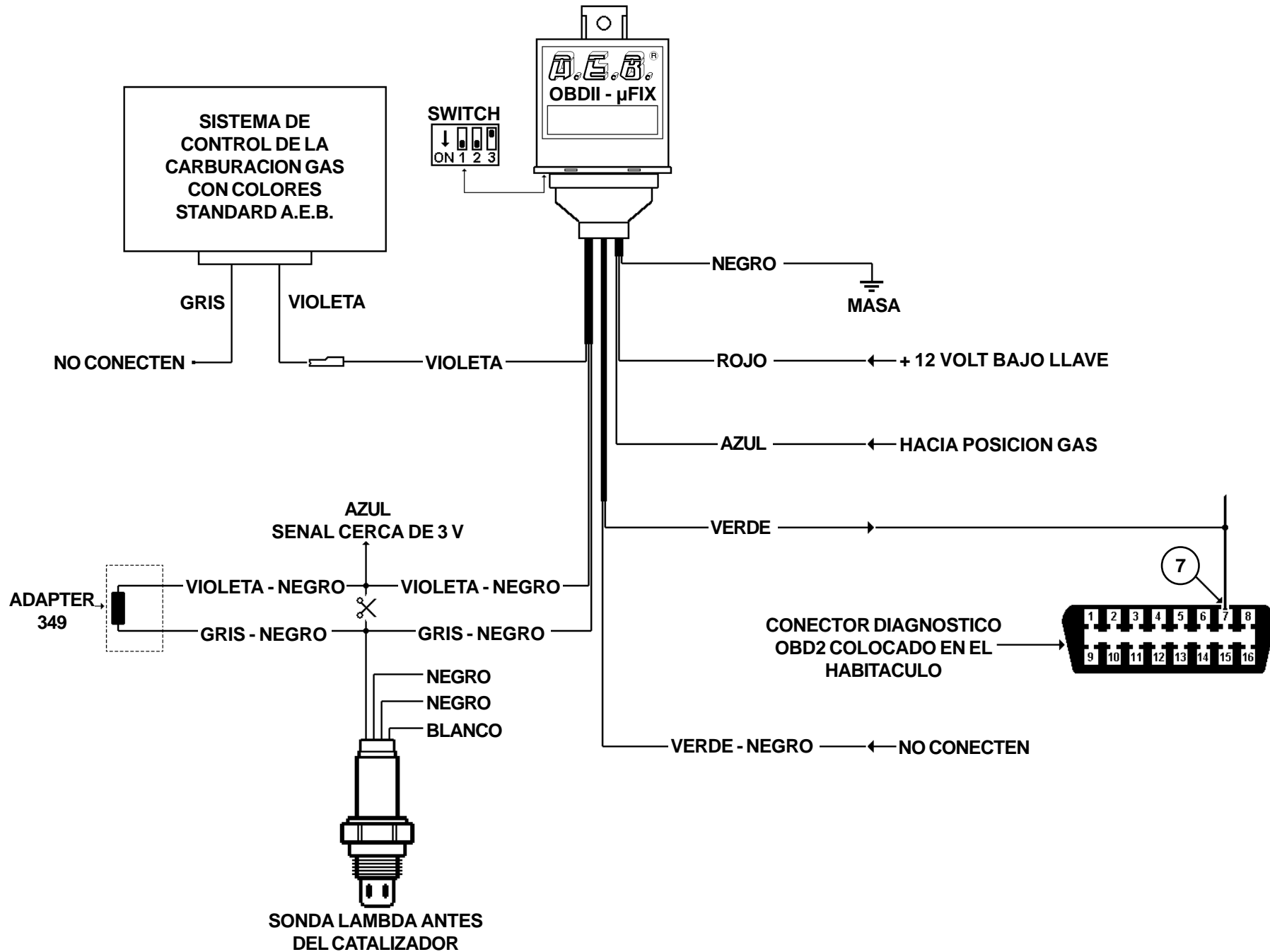

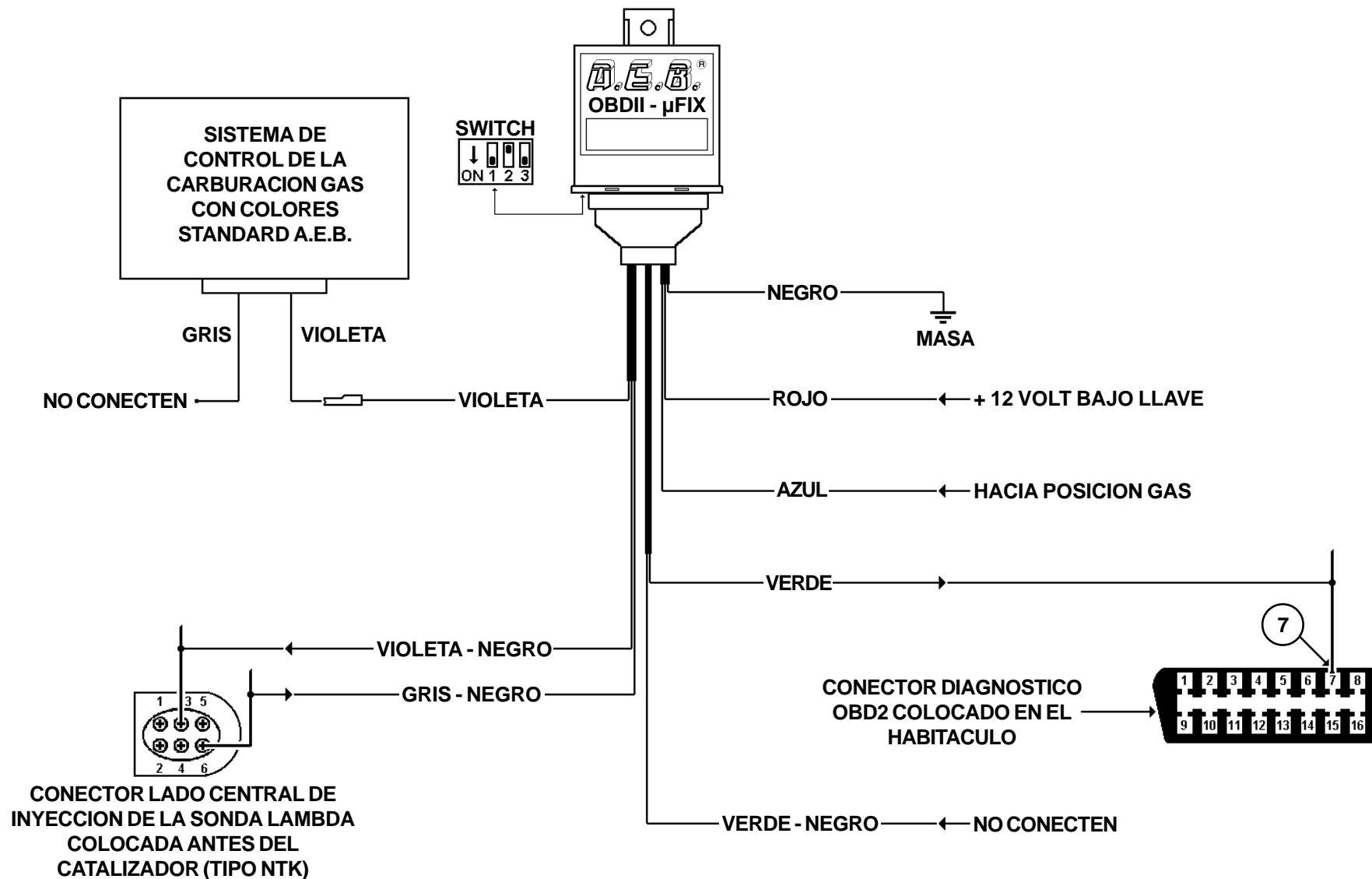

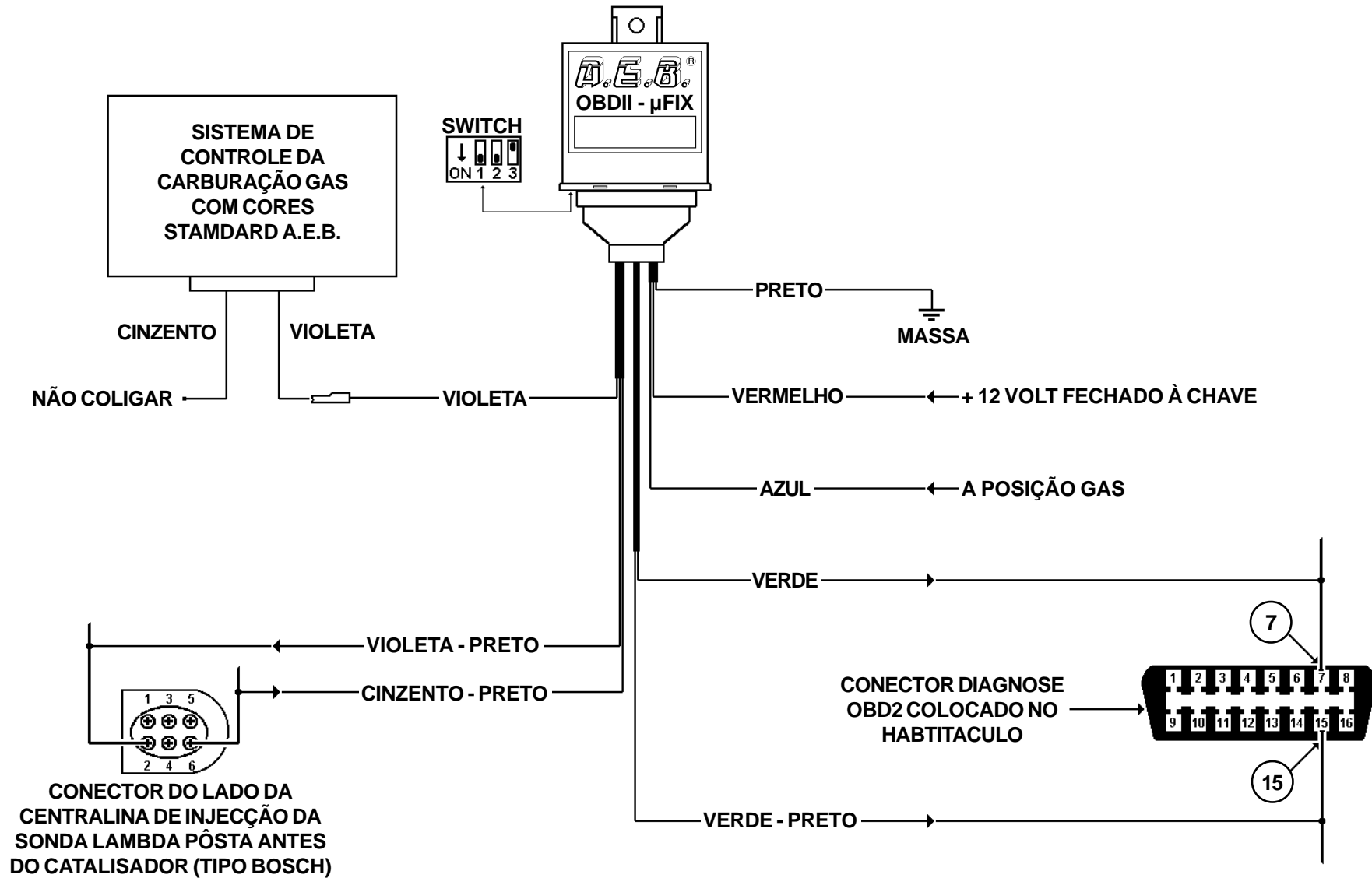

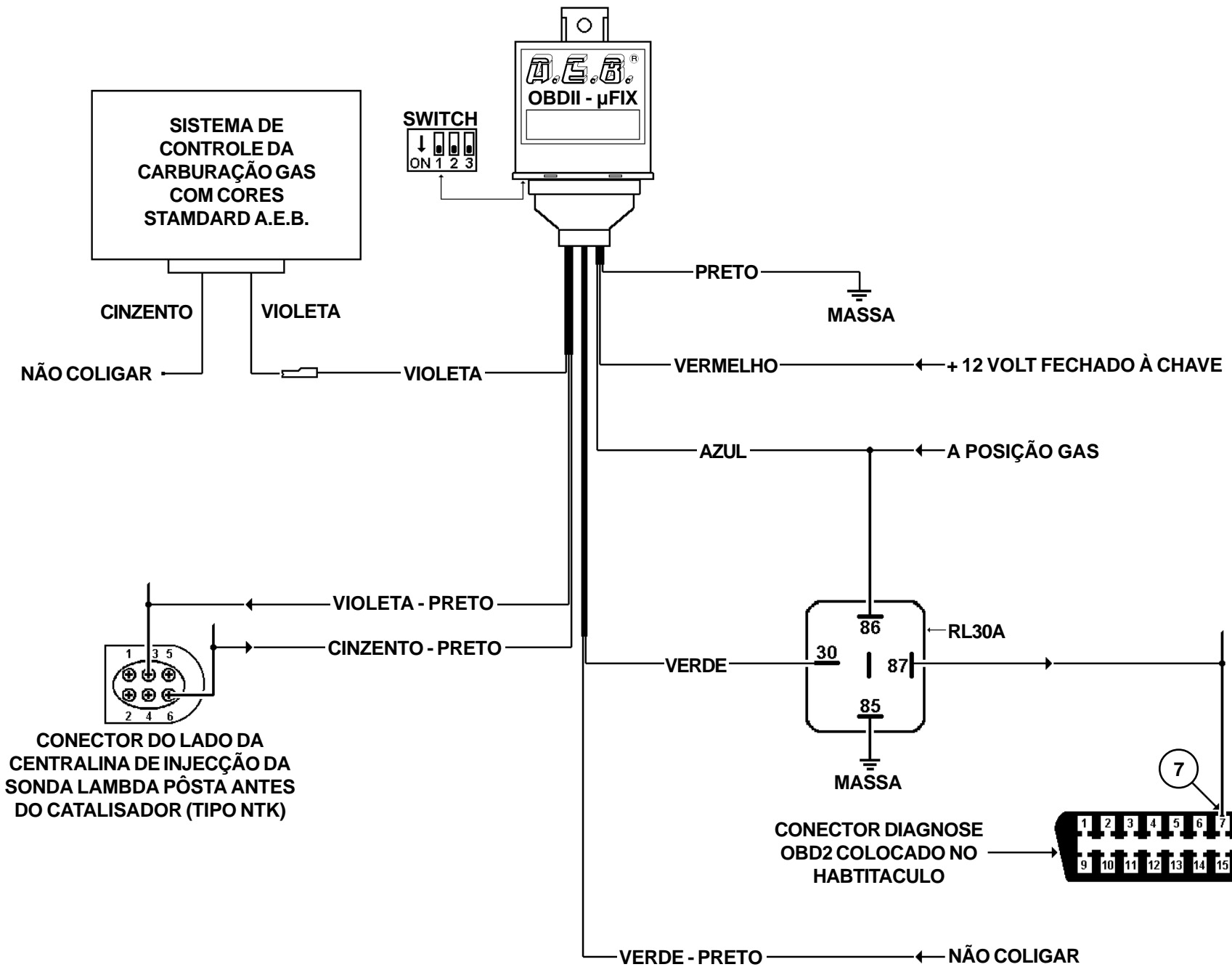

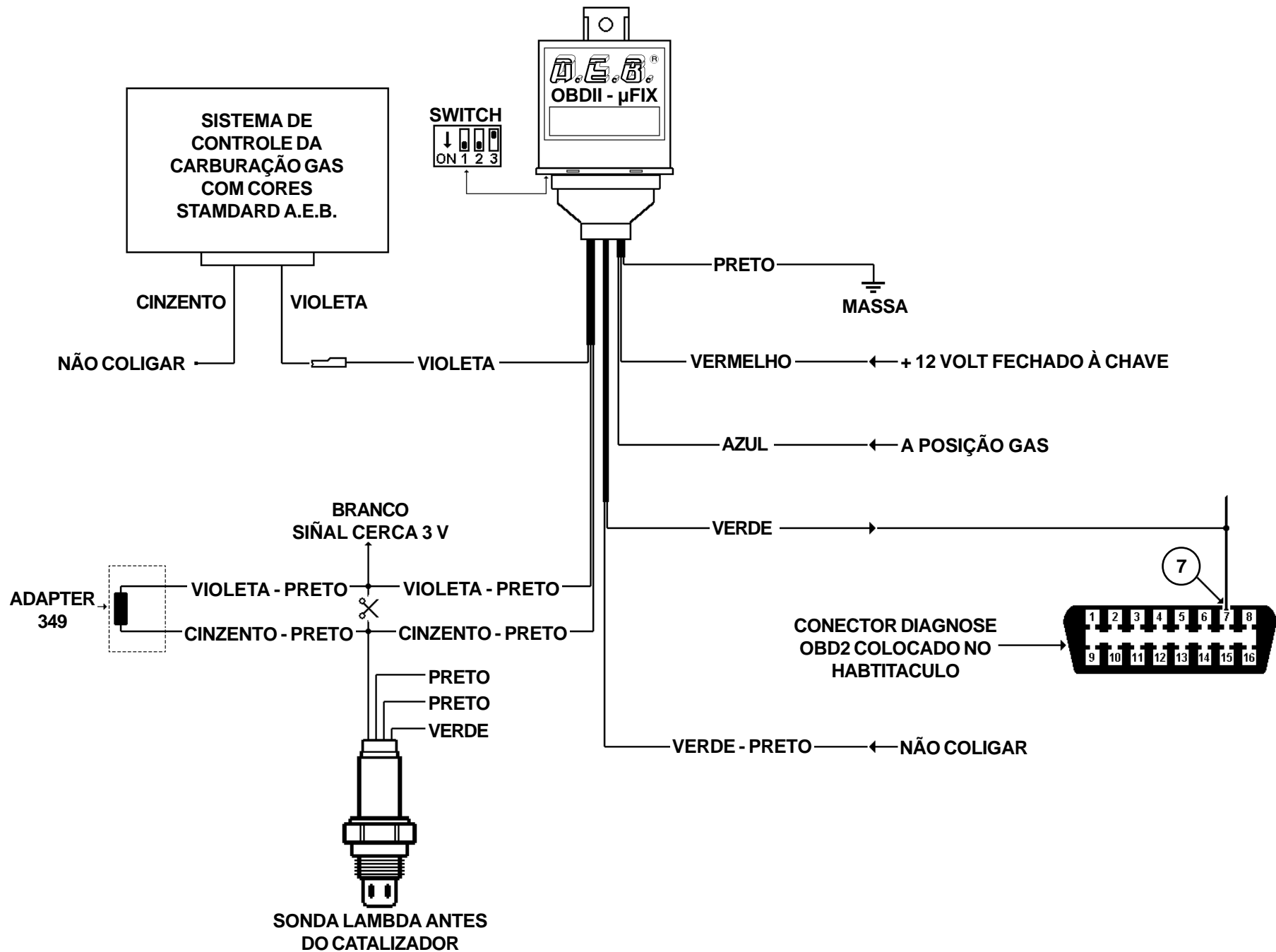

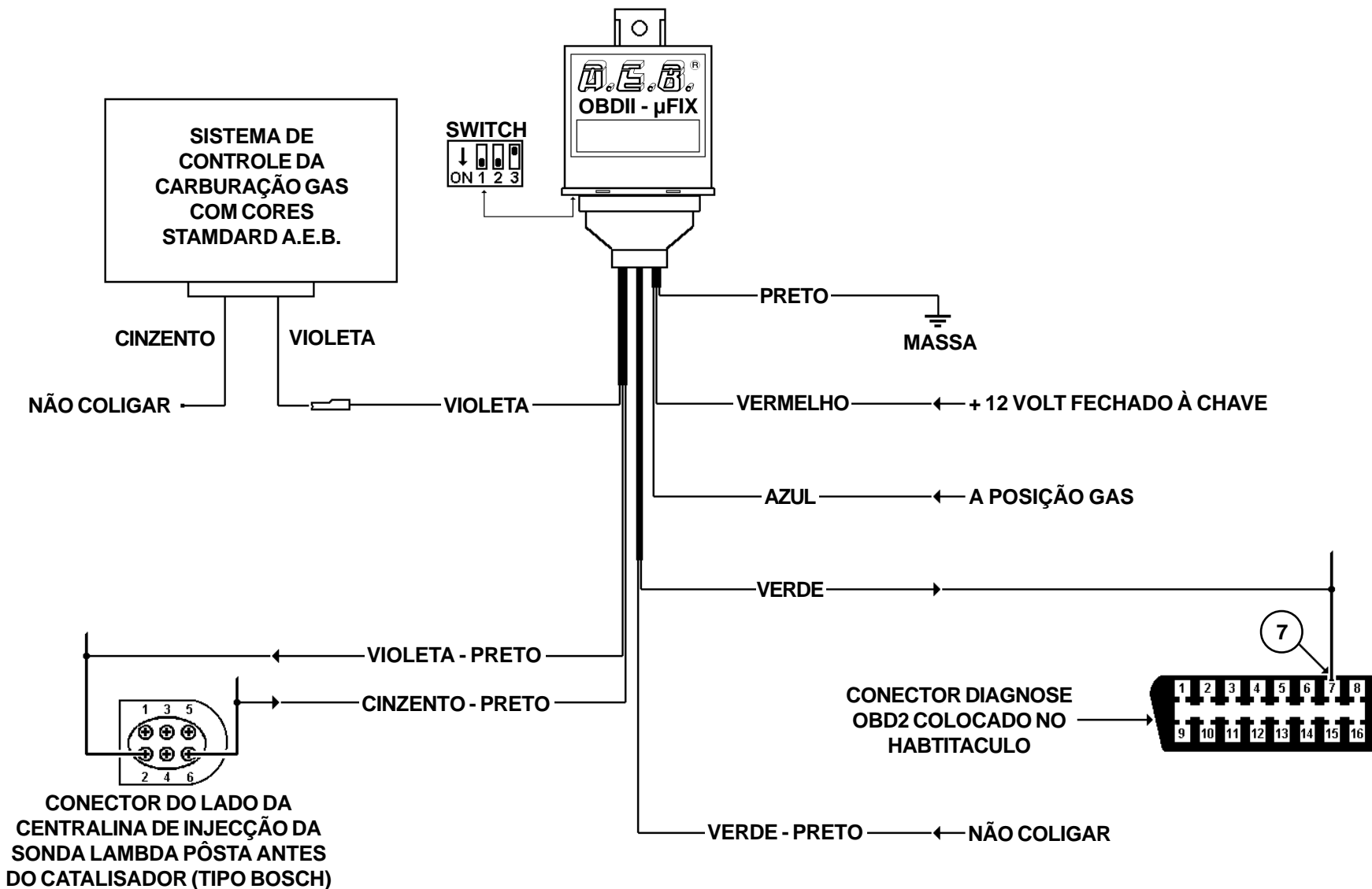

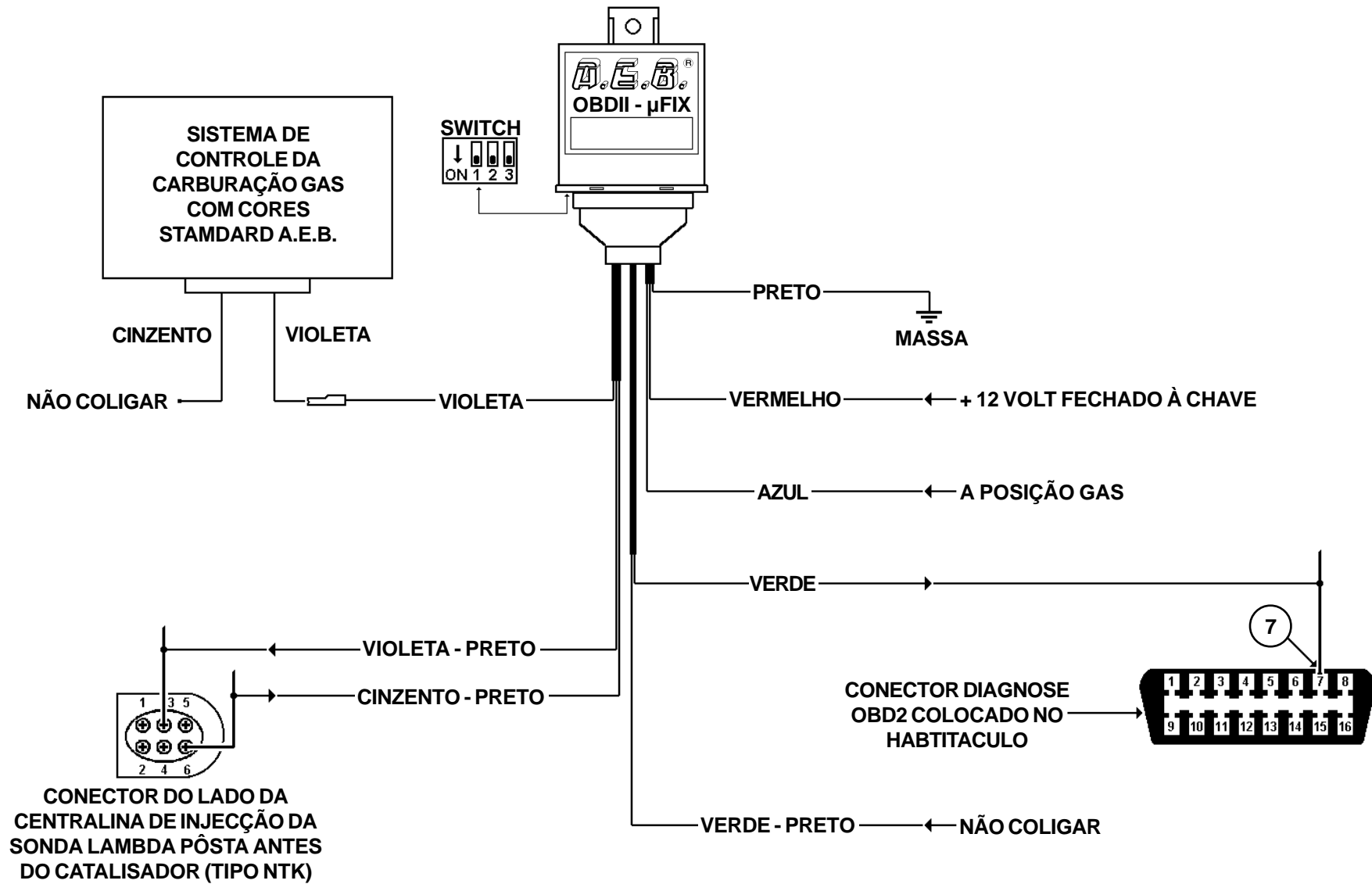

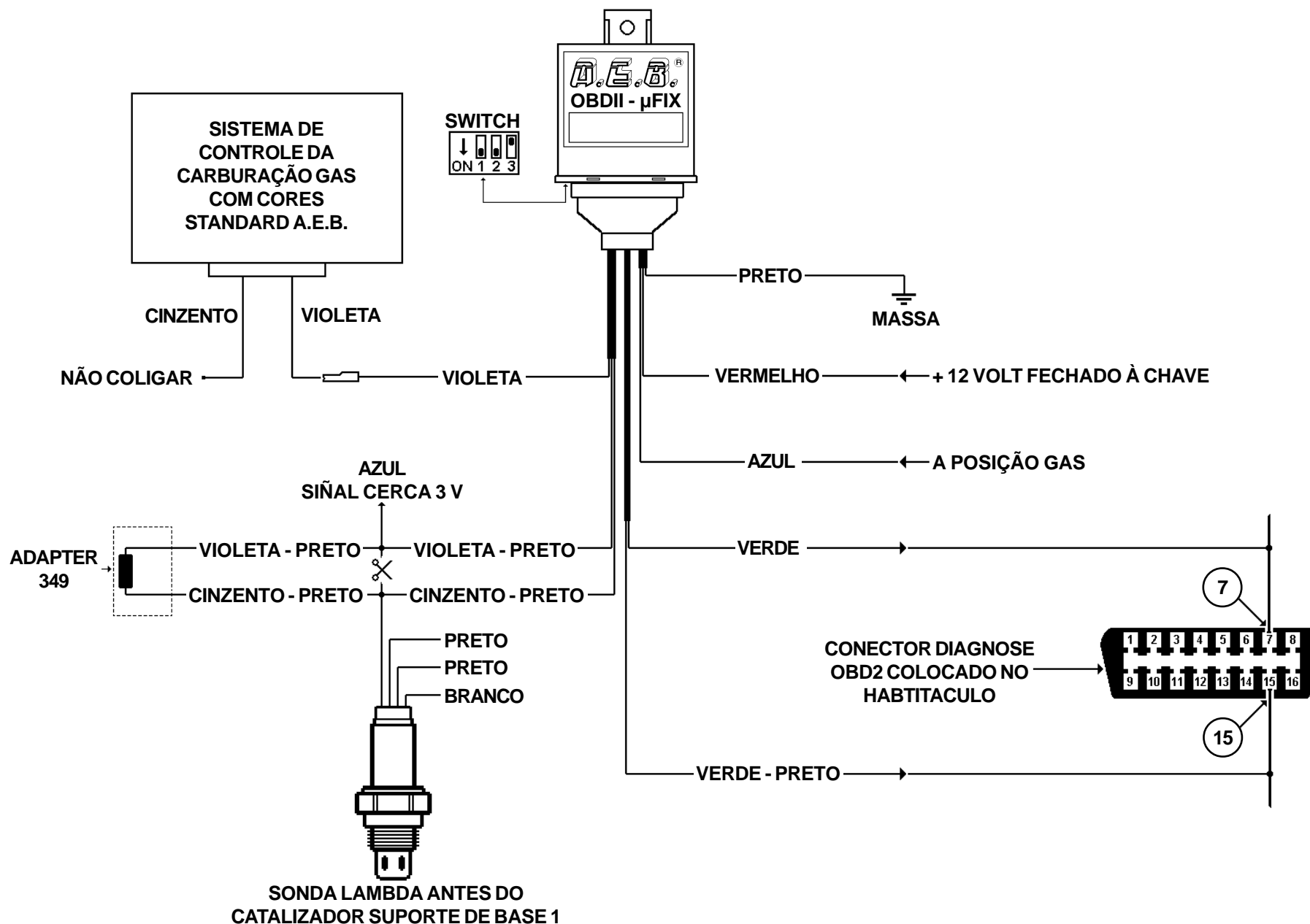

NOTA: A SUPORTE DE BASE 1 ESTÁ EM CORRESPONDÊNCIA DO CILINDRO 1



